



# Capsule Report

## Approaching Zero Discharge in Surface Finishing



**Capsule Report**

**Approaching Zero Discharge  
In Surface Finishing**

U.S. Environment Protection Agency  
Office of Research and Development  
National Risk Management Research Laboratory  
Technology Transfer and Support Division  
Cincinnati, OH 45268

## **Notice**

The U.S. Environmental Protection Agency through its Office of Research and Development funded and managed the research described here under contract number 8C-R520-NTSX to Integrated Technologies, Inc. It has been subjected to the Agency's peer and administrative review and has been approved for publication as an EPA document. Mention of trade names or commercial products does not constitute endorsement or recommendation for use.

## Foreword

The U.S. Environmental Protection Agency is charged by Congress with protecting the Nation's land, air, and water resources. Under a mandate of national environmental laws, the Agency strives to formulate and implement actions leading to a compatible balance between human activities and the ability of natural systems to support and nurture life. To meet this mandate, EPA's research program is providing data and technical support for solving environmental problems today and building a science knowledge base necessary to manage our ecological resources wisely, understand how pollutants affect our health, and prevent or reduce environmental risks in the future.

The National Risk Management Research Laboratory (NRMRL) is the Agency's center for investigation of technological and management approaches for preventing and reducing risks from pollution that threaten human health and the environment. The focus of the Laboratory's research program is on methods and their cost-effectiveness for prevention and control of pollution to air, land, water, and subsurface resources; protection of water quality in public water systems; remediation of contaminated sites, sediments and ground water; prevention and control of indoor air pollution; and restoration of ecosystems. NRMRL collaborates with both public and private sector partners to foster technologies that reduce the cost of compliance and to anticipate emerging problems. NRMRL's research provides solutions to environmental problems by: developing and promoting technologies that protect and improve the environment; advancing scientific and engineering information to support regulatory and policy decisions; and providing the technical support and information transfer to ensure implementation of environmental regulations and strategies at the national, state, and community levels.

This publication has been produced as part of the Laboratory's strategic long-term research plan. It is published and made available by EPA's Office of Research and Development to assist the user community and to link researchers with their clients.

E. Timothy Oppelt, Director

National Risk Management Research Laboratory

## Acknowledgments

This guide was prepared by Peter A. Gallerani, Integrated Technologies, Inc., and Kevin Klink, CH2M Hill. Douglas Grosse, U.S. Environmental Protection Agency (USEPA), Office of Research and Development, National Risk Management Research Laboratory (NRMRL), served as the project officer, co-author, and provided editorial assistance. Dave Ferguson, U.S. EPA, NRMRL, served as the technical advisor.

The following people provided technical review, editorial assistance, and graphic design:

Dr. David Szlag ..... USEPA, NRMRL

Paul Shapiro ..... USEPA, Office of Research and Development

Joseph Leonhardt ..... Leonhardt Plating Co.

Dr. John Dietz ..... University of Central Florida

Carol Legg ..... USEPA, NRMRL

John McCready ..... USEPA, NRMRL

# Contents

Notice .....	ii
Foreword .....	iii
Acknowledgments .....	iv
1 Introduction .....	1
2 Systematic AZD Planning .....	3
3 Process Solution Purification and Recovery Technologies .....	5
3.1 Diffusion Dialysis .....	5
3.1.1 Applications .....	5
3.1.2 Limitations .....	7
3.1.3 Secondary Stream(s) .....	7
3.1.4 Diffusion Dialysis Systems .....	7
3.2 Microfiltration .....	8
3.2.1 Applications .....	8
3.2.2 Limitations .....	9
3.2.3 Secondary Stream(s) .....	9
3.2.4 Microfiltration Systems .....	9
3.3 Membrane Electrolysis .....	9
3.3.1 Applications .....	9
3.3.2 Limitations .....	9
3.3.3 Secondary Stream(s) .....	9
3.3.4 Membrane Electrolysis Systems .....	9
3.4 Acid (Resin) Sorption .....	10
3.4.1 Applications .....	10
3.4.2 Limitations .....	10
3.4.3 Secondary Stream(s) .....	10
3.4.4 Acid (Resin) Sorption Systems .....	11
3.5 Electrowinning .....	11
3.5.1 Applications .....	12
3.5.2 Limitations .....	13
3.5.3 Secondary Stream(s) .....	13
3.5.4 Electrowinning Systems .....	13
3.6 Other Technologies .....	13
4 Rinse Purification or Concentrate Recovery Technologies .....	14
4.1 Ion Exchange .....	14
4.1.1 Applications .....	16
4.1.2 Limitations .....	16
4.1.3 Secondary Stream(s) .....	16
4.1.4 Ion Exchange Systems .....	16
4.2 Reverse Osmosis .....	17
4.2.1 Applications .....	17
4.2.2 Limitations .....	18
4.2.3 Secondary Stream(s) .....	18
4.2.4 Reverse Osmosis Systems .....	18

4.3	Vacuum Evaporation .....	18
4.3.1	Applications .....	18
4.3.2	Limitations .....	19
4.3.3	Secondary Stream(s) .....	19
4.3.4	Vacuum Evaporator Systems .....	19
4.4	Atmospheric Evaporation .....	20
4.4.1	Applications .....	20
4.4.2	Limitations .....	20
4.4.3	Secondary Stream(s) .....	20
4.4.4	Atmospheric Evaporation Systems .....	20
4.5	Other Technologies .....	20
5	Alternative Surface Finishing Processes and Coatings .....	22
5.1	Process Engineering and Re-engineering .....	22
5.2	Surface Finishing Properties .....	22
5.3	Surface Engineering .....	23
5.4	Surface Finishing Costs .....	23
5.5	Alternative Coatings and Processes .....	23
5.5.1	Alternative Electroplated and Electroless Coatings .....	23
5.5.2	Anodizing .....	23
5.5.3	Organic Coatings .....	24
5.5.4	Vapor Deposition .....	24
5.5.5	Thermal Spray .....	25
5.5.6	Hardfacing .....	25
5.5.7	Porcelain Enameling .....	25
5.5.8	Metal Cladding and Bonding .....	25
5.6	Alternative Substrates .....	25
5.6.1	Alternative Substrate Treatments .....	26
5.7	Alternative Surface Preparation .....	26
5.7.1	Alternative Stripping Processes .....	26
5.7.2	Alternative Pickling and Descaling .....	26
5.7.3	Alternative Etching .....	26
5.7.4	Alternative Cleaning .....	26
5.7.5	Alternative Cleaning Equipment .....	27
5.7.6	Forming and Fabrication .....	27
6	Existing Processes, Conditions, and Practices .....	28
7	Conclusions .....	30
8	References .....	31
Appendices		
A.	Systematic Approach for Developing AZD Alternatives .....	32
B.	Installed Costs .....	37

## Tables

1-1.	Section/Topic References from Section 8 .....	2
3-1.	Technologies for Concentrated Surface Finishing Process Solution Applications .....	6
4-1.	Typical Ion Exchange Capacities for General Resin Types (In milliequivalents per liter, meq/L) .....	16
4-2.	Technologies for Surface Finishing Rinse Applications .....	21
6-1.	General Approaches and Specific Techniques for Improving Existing Process Conditions and Practices .....	29
A-1.	Data Requirements for Characterizing Sources and Discharges .....	33
A-2.	Common AZD Benefits .....	33
A-3.	Common AZD Constraints .....	33
A-4.	AZD Alternative Evaluation Criteria .....	35
A-5.	Costs Savings and Benefits for AZD Actions .....	35
B-1.	Installed Capital Cost Ranges for Typical AZD Project Approach and Size Ranges .....	37



## Figures

3-1. Diffusion dialysis schematic. ....	7
3-2. Microfiltration system schematic. ....	8
3-3. Membrane electrolysis schematic. ....	10
3-4. Acid sorption system. ....	11
3-5. Electrowinning system. ....	12
4-1. Ion exchange system. ....	15
4-2. Reverse osmosis system. ....	17
4-3. Vacuum evaporation system. ....	19
4-4. Atmospheric evaporation system. ....	21

# 1. Introduction

This document provides technical guidance to surface finishers, environmental managers and decision makers on control technologies and process changes for approaching zero discharge (AZD). AZD is one of the key themes underlying the Strategic Goals Program (SGP), a cooperative effort among the U.S. Environmental Protection Agency (EPA), the American Electroplaters and Surface Finishers Society, the National Association of Metal Finishers, and the Metal Finishing Suppliers Association to test and promote innovative ideas for improved environmental management within the metal finishing industry. For more information on this program, see <http://www.strategicgoals.org/>

In its broadest sense, “zero discharge” means no discharge to any media. More commonly, zero discharge focuses on zero wastewater discharge. This report presents information and strategies for approaching zero discharge for concentrated process fluids and associated rinsewaters from surface finishing manufacturing. This focus is intended to minimize discharges of spent and/or underused process fluids. Specific SGP goals addressed in this report are:

- Improved use of process chemistry (SGP goal is 98% metals utilization on product);
- Water use reduction (SGP goal is 50% reduction); and
- Hazardous waste emissions reduction (SGP goal is 50% reduction in metals emissions to air and water, and 50% reduction in hazardous waste sludge disposal).

The following list provides a section-by-section overview of this report:

## **Section 2: Systematic AZD Planning**

This section and related Appendix A provide key considerations for planning through implementation of any AZD project. Without systematic planning and appropriate implementation, an AZD project can fail or fall short of overall potential. The techniques and technologies presented in Sections 3 through 6 should be pursued within a systematic framework. Specific approaches within these general categories may be used independently or in combination to meet specific AZD goals.

## **Section 3: Process Solution Purification and Recovery Technologies**

This section presents technologies for in-plant purification and maintenance of surface finishing process solutions and rinses. Pursuing this approach results in reduced discharges through improved use of process solutions.

## **Section 4: Rinse Purification or Concentrate Recovery Technologies**

This section presents technologies for purification of rinses for recycling to surface finishing processes. Pursuing this approach can result in a combination of improved use of process solutions and water.

## **Section 5: Alternative Surface Finishing Processes and Coatings**

Section 5 advances alternative surface finishing processes and coatings. Most of the alternative surface finishing processes and coatings can result in substantial reductions in discharges compared to traditional processes.

## **Section 6: Improving Existing Process Conditions and Practices**

This section presents techniques for modifying existing process operations and plant practices. Reduced discharges can result in modifications that provide for better process optimization.

## **Section 7: Conclusions**

## **Section 8: References**

## **Appendix A: Systematic Approach for Developing AZD Alternatives**

This is a supplement to Section 2 that presents a systematic method to guide the identification, development, and implementation of AZD actions.

## **Appendix B: Installed Costs**

This appendix provides installed cost information.

Table 1-1 provides a topical section cross reference.

**Table 1-1** Section/Topic References from Section 8

Section	Topic	References
Section 2	Systematic AZD Planning	9, 14, 15
Section 3	Process Solution Purification and Recovery Technologies	
	• Ion Exchange	2, 3, 4, 5, 6, 7, 9, 10
	• Reverse Osmosis	2, 3, 4, 5, 6, 9
	• Vacuum Evaporation	2, 3, 4, 5, 7
	• Atmospheric Evaporation	3, 4, 6, 7, 9, 17
	• Electrodeionization	5
	• Electrodialysis	3, 4, 5, 9, 17
	• Electrowinning	3, 6, 9
	• Nanofiltration	5, 9
	• Polymer Filtration	4, 5
	• Ultrafiltration	3, 4, 5, 6, 9
Section 4	Rinse Purification or Concentrate Recovery Technologies	11, 12, 18
Section 5	Alternative Surface Finishing Processes and Coatings	1, 2, 4, 5, 13, 15, 16, 17, 19
Section 6	Improving Existing Process Conditions and Practices	1, 2, 9
Section 7	Conclusions	1, 6, 9
Appendix A	Systematic Engineering Approach	6, 9, 14, 15
Appendix B	Installed Costs	1, 5, 7, 8, 9, 10, 17

## 2 Systematic AZD Planning

Systematic AZD solutions can be developed by integrating holistic source reduction planning, including considerations for multiple sources, composite solutions, and life cycle process and facility optimization. Nine key considerations for systematic AZD planning are:

1. Is the AZD target a fixed endpoint or an optimization point?

The type of AZD target frames the overall AZD options and the planning approach. A fixed endpoint could be below or beyond the most cost-effective (optimal) AZD target. For example, assume that for a particular wastewater stream, the most cost-effective (life cycle) approach would be to use single-stage reverse osmosis to recycle water and reduce wastewater by 80%. A less-than-optimal AZD target might be to pursue a 50% reduction goal, and a beyond-optimal AZD target might be to pursue a 90% or 100% wastewater reduction goal. These endpoint goals may be based on specific drivers or constraints, such as cost. As zero discharge is approached, the costs for incremental discharge reductions can increase significantly in proportion to the benefits achieved.

2. What tradeoffs are there between point source and more combined reduction strategies?

Point source AZD strategies involve the use of bath or rinse purification systems for individual tanks or sources. Alternative strategies might include combining compatible streams from different processes for purification/recovery. This could include use of single fixed location recovery systems (e.g., centralized reverse osmosis/ion exchange for recycling rinswaters from several process lines). Another combined strategy would be to use a mobile system to perform intermittent purification/recovery of several point sources. For example, a single mobile diffusion dialysis system might be used to purify/recycle several different acid baths. Combined strategies may be more cost-effective, due to economy of scale, unless there are substantially increased plant interface requirements. Point source systems may offer more flexibility, redundancy, and reliability.

3. What tradeoffs are there between up-the-pipe pollution prevention and end-of-pipe pollution control?

Up-the-pipe systems can reduce end-of-pipe system requirements. For example, bath purification and water recycling can combine to reduce wastewater treatment system contaminant loading and hydraulic sizing. In-plant systems may also produce byproducts requiring waste treatment or management.

4. What combination of technology, technique and substitution would provide the best overall solution?

Sections 3, 4, 5, and 6 present a range of technologies, techniques and process substitution strategies for AZD. Integrated approaches should be considered as potential improvements over single-approach solutions.

5. What future production and facility scenarios should be considered?

AZD solutions should consider overall life cycle and future production and facility needs. Potential future requirements may lead to modified AZD alternatives, or more allowances for change. Defining future scenarios may lead to specific phased implementation plans, or decisions to accelerate/delay plans for facility renovation.

6. Are AZD solutions well defined?

Whether dealing with a single-point source, multi-process or overall facility alternatives, all significant impacts should be identified and implemented to define requirements for a comprehensive AZD solution. Those include process byproducts, cross-media impacts, plant interface and utility requirements, operations and maintenance requirements. A particular approach may be able to meet the primary AZD performance requirement (e.g., 90% acid reuse) but may present implementation problems caused by other aspects (air discharge requiring ventilation system, permitting, etc). Comprehensive definition

of AZD alternatives is important to identify barriers to implementation.

7. How does the surface finishing process chemistry change with production?

One key dimension is understanding the chemistry for each process step and how the chemistry changes during production cycles, including:

- transfer or transformation of process chemicals rendering them unavailable for production and
- generation of contaminants that reduce the useful life of process chemicals.

Changes in process chemistry can necessitate the need to purchase fresh or make-up process bath chemicals. Similarly, the increased volume of waste process baths and rinses requiring treatment results in more waste treatment chemicals and corresponding increases in waste generated.

8. What opportunities are there to use existing systems? New systems?

Enhancements to existing systems may produce significant benefits at low cost and overall effort. Additional capital for new systems may result in overall net beneficial gains in capacity, productivity, reduced wastes, automation, and space. Beneficial process changes may also result from eliminating or consolidating processes.

### 3. Process Solution Purification and Recovery Technologies

Purification of surface finishing process solutions allows for extended use of bath chemistries while reducing wastes and chemical purchases. Without solution purification, process cycle times often increase over time as the result of increased contaminant loading and decreased free acid or alkali concentrations. This is especially true of stripping, pickling, etching and cleaning process solutions. Process contaminants are normally controlled through periodic solution dumps and drag-out. Continuous, steady-state bath maintenance can result in more constant production rates and quality.

This section presents technology descriptions, applications and limitations, secondary waste stream identification, and system components and configurations for five process solution purification technologies in surface finishing applications:

1. Diffusion dialysis
2. Microfiltration
3. Membrane electrolysis
4. Acid (resin) sorption
5. Electrowinning

In addition, Table 3-1 features eight technologies, considered to show promise for limited surface finishing process solution applications:

1. Adsorption filtration
2. Crystallization
3. Electrodialysis
4. Ion exchange
5. Liquid ion exchange
6. Nanofiltration
7. Ultrafiltration
8. Vacuum evaporation

#### 3.1 Diffusion Dialysis

Diffusion dialysis is a membrane separation process that typically uses an anionic exchange membrane to transport acid anions and protons from waste acid solutions into deionized water streams. This process recovers useable “free” acid commonly wasted when metals contaminant buildup levels exceed processing criteria. Consequently, the resultant acid bath is dumped. Such wasted free acid consumes significant quantities of neutralization chemicals and must be replaced in the process. Free acid readily diffuses across the membrane in proportion to a concentration gradient. Metal cations diffuse at a much slower rate due to their positive charge and the negative charge functionality of the anionic exchange membrane. Typical acid recovery rates are 80-95% and typical metal rejection rates are 60-95%.

Diffusion dialysis separations use a membrane consisting of a series of alternating anion exchange membranes and separators that form countercurrent fluid distribution paths. Contaminated acid (feed) enters on one side and deionized (DI) water is fed via countercurrent on the other side. Concentration gradients exist across the membranes. Free acid is transported from the waste acid into the countercurrent DI water stream via diffusion. Metals in the feed liquor are rejected by the membrane to a large extent, and are removed in the waste stream (retentate) for metal recovery or treatment. Free acid is collected in the DI water (dialysate) for acid recovery. Typically, the feed and exit stream flow rates are approximately equal. Figure 3-1 shows the basic function of diffusion dialysis.

The concentration of recovered acid will normally be lower than that of the feed acid, and make-up acid must be added to bring the concentration up to the process level. When the feed has a significant salt concentration, the concentration of recovered acid can exceed the concentration of the feed acid.

For diffusion dialysis processing, an increase in membrane area per unit of acid flow increases the acid recovery rate. If the flow rate of DI water increases, the acid recycling rate increases and the recycled acid concentration decreases.

##### 3.1.1 Applications

Diffusion dialysis is a purification/recycling technology that can be used to maintain or reclaim spent or contaminated acids where acid concentrations are greater than 3% by

**Table 3-1.** Technologies for Concentrated Surface Finishing Process Solution Applications

Technology	Description	Status	Applications and Limitations
Adsorption Filtration	Granulated polypropylene felt or other lipophilic filter media is placed in filter housings and used for removal of oils by adsorption.	Emerging	Removes mineral oil derivatives from aqueous cleaning solutions to less than 10 ppm range. Beneficial cleaner components are not significantly removed.  Operates over full pH range and at temperatures up to 200 °F (95 °C).
Crystallization	Various evaporation and cooling systems are used to bring solutions to a super-saturation point where solid crystals form and can be separated from solution.	Commercial technology; limited surface finishing applications	Applicable for some etching or pickling baths with relatively high metals concentrations where controlled metals removal and recovery are beneficial (e.g., removal and recovery of copper sulfate from peroxide-sulfuric etch solutions).  Applicable for removal of carbonates to maintain alkaline and cyanide plating solutions. Used for acid pickling, aluminum etchant and cyanide/alkaline plating bath maintenance.
Electrodialysis	Anions and cations are removed from solutions with an applied electric field in cells with alternating anion- and cation-permeable membranes.	Commercial technology; limited surface finishing applications	Used for regeneration of spent electroless nickel baths. Sodium, iron and zinc cations are removed through a cation membrane. Sulfate and orthophosphate anions are removed through an anion membrane.
Liquid/liquid ion Exchange	Ionic contaminants are removed from process solutions into immiscible primary liquid extraction solutions. Secondary liquid extraction solutions are used to remove the contaminants and to regenerate the primary extraction solution.	Commercial technology; limited surface finishing applications	Ammoniacal etch solutions have been regenerated by removal of copper, with a closed-loop extraction solution system.
Ion Exchange	Ions in solution are selectively removed by exchanging positions with resin-functional groups.	Commercial technology; commonly used in surface finishing rinse water applications  Limited concentrated solution application.	Used in some applications for tramp metal removal from concentrated process solutions. A typical application is the removal of iron from chromium plating solutions. Removal by ion exchange is not viable for process solutions more concentrated than ion exchange regenerant solutions. Concentrated process solutions may also degrade resins.
Nanofiltration	Membrane filtration manufactured for larger size rejection (rejects molecules larger than 0.001 to 0.008 microns) than reverse osmosis. Preferentially rejects some larger ions and passes others.	Commercial technology; limited surface finishing applications	Used for separation of metals from spent acid solutions, or from reverse osmosis concentrates for acid purification/recycling.
Ultrafiltration	Membrane filtration process that passes ions and rejects macromolecules (0.005 to 0.1 micron).	Commercial technology; limited surface finishing applications	Removes organics from process solutions. For aqueous cleaners, removes more contaminants compared to microfiltration, but may also remove significantly more of the beneficial cleaner constituents.
Vacuum Evaporation	Reduced pressure and elevated temperature combine to separate constituents with relatively high volatility from constituents with lower volatility.	Commercial technology; limited use for surface finishing concentrates (more commonly used for rinse applications)	Contaminants with lower volatility than process solutions can be evaporated (e.g., removal of water from an acid solution). Evaporating the process solution (e.g., acid distillation) from contaminant phases with higher volatility can also purify process solutions. Multiple stages may be used to increase separation purity, to reduce energy requirements, or to accomplish multiple phase separations.

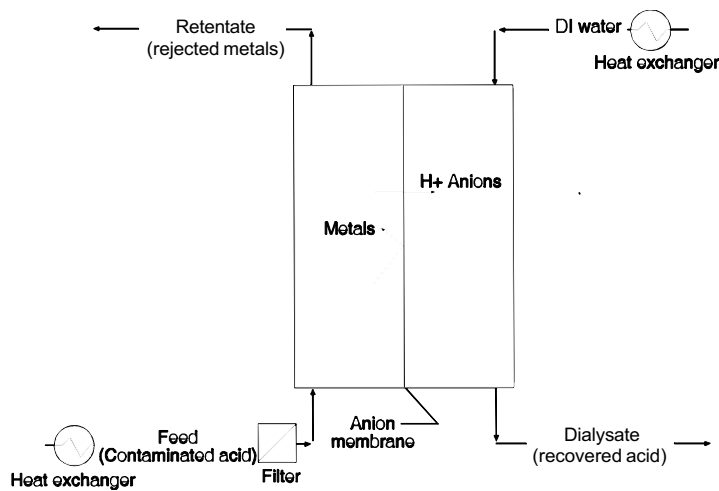

Figure 3-1. Diffusion dialysis schematic.

weight. Diffusion dialysis is most typically used where contaminant metals concentrations are less than 1 gram per liter. Surface finishing process solutions amenable to the use of diffusion dialysis include:

- Hydrochloric acid (HCl) pickle and strip solutions
- Sulfuric acid (H<sub>2</sub>SO<sub>4</sub>) anodize solutions
- Sulfuric acid pickle and strip solutions
- Nitric acid (HNO<sub>3</sub>) pickle and strip solutions
- Nitric acid/hydrofluoric acid (HNO<sub>3</sub>/HF) stainless steel pickling solutions
- Hydrochloric acid/sulfuric acid (HCl/H<sub>2</sub>SO<sub>4</sub>) aluminum etch solutions
- Methane sulfonic acid (MSA) solutions

### 3.1.2 Limitations

Limitations in using diffusion dialysis to recover surface finishing process acids include:

- Acids not highly dissociated (e.g., phosphoric acid) will not diffuse across the membrane.
- Complexed metal anions (e.g., fluorotitanium anions) can readily diffuse across the anion exchange membrane and are not efficiently separated from the acid.

- Cooling is typically needed if influent waste acid temperature exceeds 122 °F (50°C).
- Heating may be needed for low-temperature influent waste acid. A temperature drop of 3.6 °F (2°C) reduces the acid recycling rate by approximately 1.5%.
- Solvents can cause membrane swelling.
- Strong oxidizing substances (e.g., chromic acid) can cause membrane deterioration.

### 3.1.3 Secondary Stream(s)

The depleted acid waste stream (after diffusion dialysis processing) is approximately equal in volumetric flow to the waste acid influent. Depending on the application-specific acid removal and metals rejection rates, the depleted acid waste stream (retentate) typically contains 5 to 20% of the acid and 60 to 95% of the metals from the influent waste acid stream. This stream is usually sent to wastewater treatment.

### 3.1.4 Diffusion Dialysis Systems

Typical diffusion dialysis system components include:

- Membrane stack, including plate and frame, membrane spacers, and special anion exchange membranes
- Feed and exit stream tanks and pumps
- Process I&C and electrical
- Acid pre-filter (some applications)
- DI water system (some applications)



- Heat exchanger (some applications)

Diffusion dialysis systems can be used for batch or continuous flow applications. Small systems are often configured as mobile units.

### 3.2 Microfiltration

Microfiltration (MF) is a membrane filtration technology that uses low applied pressures in the range of 3-50 psi (20 to 350 kPa) with pore sizes in the range of 0.02 to 10 microns to separate relatively large particles in the macromolecular to micro particle size range (approximate molecular weights > 100,000).

Microfiltration is typically configured in a crossflow filtration pattern, rather than in a conventional, pass through configuration. In the crossflow configuration, the feed solution flows parallel to the filter media (membrane) and splits into a permeate (filtrate) stream, which is the cleaned solution that passes through the membrane, and a concentrate (retentate or reject) stream that contains the contaminants rejected by the filter membrane. A major benefit for the crossflow configuration is that relatively high-solids streams may be filtered without plugging. Figure 3-2 presents a microfiltration system schematic for process fluid purification applications.

Four primary operating parameters influence crossflow filtration performance:

1. Trans-membrane pressure difference
2. Flow velocity parallel to the membrane
3. Temperature
4. Bulk stream component concentration

Increasing trans-membrane pressure will increase flux until a constant flux point is reached. Increases in trans-

membrane pressure above the constant flux point will result in a thicker, more compact particle layer at the filtration surface.

The flow velocity parallel to the membrane influences the shearing forces on the particle layer surface. High velocity results in a constant layer thickness, and a more constant flux. Generally, the higher the tangential velocity, the higher the flux. Higher flux results in a greater pressure drop in the direction of tangential velocity, and higher energy consumption. In most cases, temperature increases will result in a lower viscosity of the liquid to be filtered. Lower viscosity influences flow through and parallel to the membrane. Temperature changes may cause components to be precipitated or dissolved, greatly impacting flux. Increases in bulk stream component concentration cause a decrease in flux through the membrane. This effect can vary, depending on the characteristics of the filtered solution.

#### 3.2.1 Applications

Microfiltration applications include:

- Cleaner aqueous purification
- Removal of oil and grease from process baths
- Wastewater treatment applications (replaces clarification and polishing filters)

Microfiltration has become a popular process for continuous or batch maintenance of aqueous cleaning solutions. Through proper membrane selection, it is possible to remove both oily and solid solution contaminants selectively from many proprietary industrial cleaners. Chemical suppliers can assist in the selection of aqueous cleaners and microfiltration membranes to optimize the separation of contaminants from cleaning agents such as surfactants.

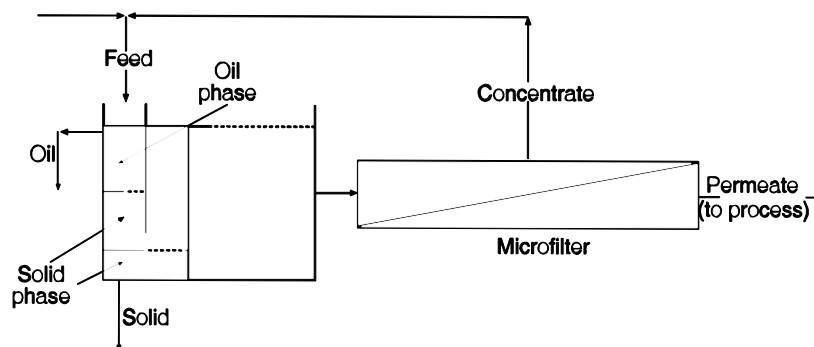

Figure 3-2. Microfiltration system schematic.

### 3.2.2 Limitations

Since cleaning agents are typically removed along with oil, grease and dirt, the bath must be amenable to replenishment with make-up chemical additives. Cleaners with relatively high silicate concentrations are generally less amenable to purification with microfiltration. Aluminum cleaning solutions are typically not recycled with microfiltration due to buildup of dissolved aluminum. Recent advances in membrane technology may extend the range of microfiltration application to silicated cleaners.

### 3.2.3 Secondary Stream(s)

The separated oil, grease and dirt from one or more concentrated stream phases require waste treatment and/or disposal. The relatively low-density oil phase is usually skimmed off. The relatively dense dirt/grease phase is removed in a separate bottom phase for disposal.

### 3.2.4 Microfiltration Systems

Typical microfiltration system components include:

- Membranes and housings
- Working tank (containing process fluid that is circulated through the microfilter, and zones for light and dense phase separations)
- Oil and dense phase contaminant removal systems (manual or automatic)
- Membrane cleaning systems (chemical cleaning and/or back pulsing system)

## 3.3 Membrane Electrolysis

Membrane electrolysis uses one or more ion-selective membranes to separate electrolyte solutions within an electrolysis cell. The membranes are ion-permeable and selective. Cation membranes pass cations such as Cu and Al, but reject anions. Anion membranes pass anions, such as sulfates and chlorides, but reject cations.

Membrane electrolysis can regenerate process solutions through two primary mechanisms: (1) Selective transfer of ions from the process solution, across the membrane, into an electrolyte solution and (2) Regenerating oxidation states/ionic forms of key constituents in the process solution through electrode electrochemical reactions.

A common configuration for removing cation contaminants from surface finishing process solutions uses a cation-specific membrane coupled with a two-cell compartment drawing an electrical potential applied across the membrane. One cell contains an anode with the anolyte solution; the other contains a cathode with the catholyte solution. Figure 3-3 presents a flow schematic for a two-cell membrane electrolysis system.

The anolyte solution is typically the spent process solution requiring regeneration. Contaminant cations are removed

from the anolyte solution and transferred into the catholyte solution. Anode and cathode reactions occur based on the relative electronegativity and concentration of specific ions in each solution, as water decomposes.

### 3.3.1 Applications

Membrane electrolysis has been used with chromic acid-based solutions, including chromium plating, chromic acid anodizing, etchants and chromating solutions. Trivalent chromium can be beneficially reoxidized at anodes to hexavalent chrome. Contaminant metals are transported into the catholyte. Membrane electrolysis has also been applied to various acid-based etchants, stripping and pickling solutions to remove contaminant metals. Multi-cell systems with special anolyte and/or catholyte solutions have been used with highly corrosive acids, such as nitric and hydrofluoric, to isolate the electrodes. Membrane electrolysis can be used on a batch or continuous basis, and is often configured as a mobile unit for smaller point-source applications.

### 3.3.2 Limitations

Limitations of membrane electrolysis:

- Special materials of construction and cell configurations may be required for processing highly corrosive fluids.
- Fume collection and treatment may be required if hazardous gases are generated in electrode reactions.
- Anionic metal complexes require pretreatment prior to removal across a cation exchange membrane.
- Operating temperatures are typically limited from 60°F to 140°F.
- Oil, grease and solvents can adversely affect membranes.
- Suspended solids and precipitates can clog membranes.

### 3.3.3 Secondary Stream(s)

Contaminant metals are typically transferred from process solutions into catholyte solutions. The catholyte solution is periodically replaced. The spent catholyte solution is usually a small percentage of the treated process solution volume, and contains concentrated removed metals. Spent catholyte solutions can be processed for metals recovery or handled as waste.

### 3.3.4 Membrane Electrolysis Systems

Typical membrane electrolysis system components include:

- Cell with anolyte and catholyte compartment(s)

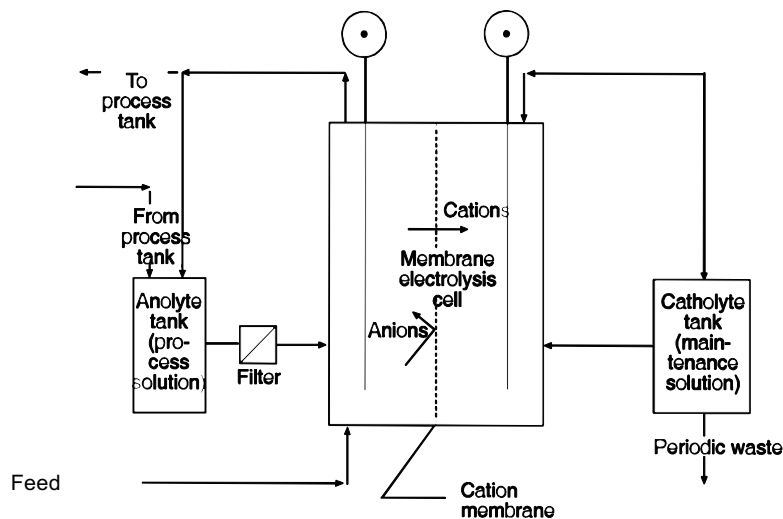

Figure 3-3. Membrane electrolysis schematic.

- Ion exchange membrane(s)
- Rectifier, buss bars, and bussing
- Anolyte and catholyte process tanks, pumps, and piping systems
- Process instrumentation and controls (if needed)
- Ventilation systems (if needed)
- Sulfuric or nitric acid pickling, etching, or brightening baths for copper or brass
- Nitric/hydrofluoric acid pickling baths used for processing stainless steel
- Phosphoric and/or sulfuric acid baths for stainless steel or aluminum electropolishing
- Cation ion exchange acid regenerant solutions

Membrane electrolysis systems can be configured as multi-cell systems to enhance capacity. Three compartment cells are used for special applications where the electrodes must be isolated from the feed stream. A range of selective and custom-made electrodes are available for removal of special and noble metals.

### 3.4 Acid (Resin) Sorption

Acid (resin) sorption is a technology used primarily for recovering acids from surface finishing etch and pickle solutions. Configured similarly to ion exchange, resins are designed to selectively adsorb mineral acids while excluding metal salts (adsorption phase). Purified acid is recovered for reuse when the resin is regenerated with water (desorption phase). Figure 3-4 shows a general process flow diagram for acid sorption.

#### 3.4.1 Applications

Acid sorption is used to separate dissolved ionic metal contaminants from acid baths. Applications include:

- Sulfuric acid anodizing baths for aluminum
- Sulfuric or hydrochloric acid pickling baths for steel and galvanized steel

#### 3.4.2 Limitations

Acid sorption limitations include:

- Not applicable for some highly concentrated acids.
- Should not be used on acids with anionic complexes that sorb to the resin, thus reducing acid recovery.
- Application-specific temperature limitations should not be exceeded (e.g., approximately 90°F for nitric acid, and up to 160°F for sulfuric or hydrochloric acid).

#### 3.4.3 Secondary Stream(s)

The acid sorption process recovers only a portion of the free or unused acid. It does not recover any of the combined acid (salt). As a result, approximately 35 to 70% of the total acid used is incorporated into a waste stream from the process and will require treatment. Depending on the metal involved, treatment will range from conventional neutralization (pH adjustment with caustic) to metals removal (e.g., precipitation).

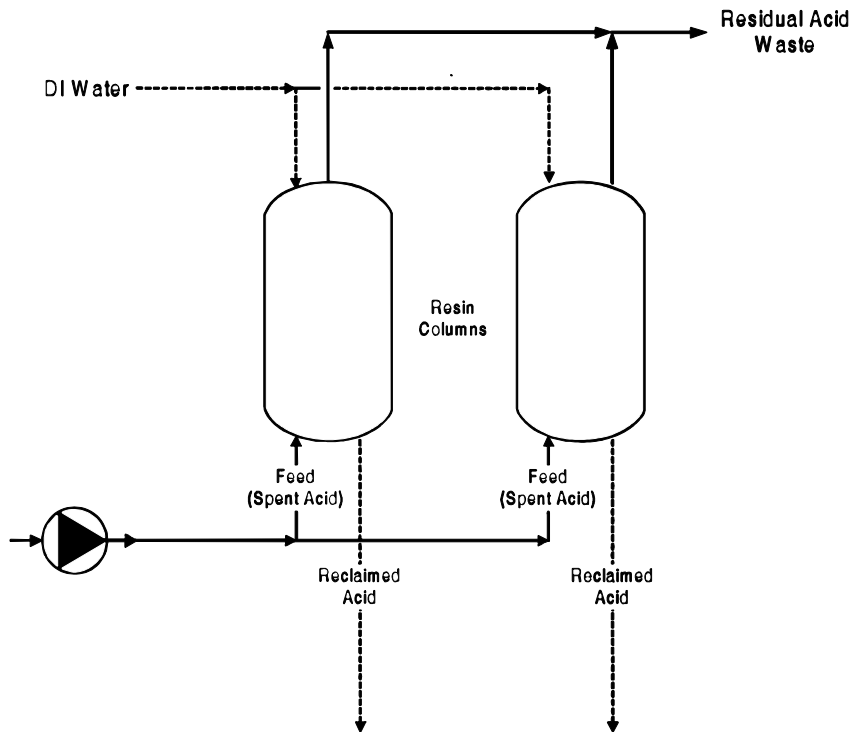

Figure 3-4. Acid sorption system.

### 3.4.4 Acid (Resin) Sorption Systems

Typical acid sorption system components include:

- Resin columns with resin
- Feed and discharge pumps, piping, and tanks
- Process automation for adsorption and desorption cycling
- Prefiltration
- Feed stream cooling

### 3.5 Electrowinning

Electrowinning (also called electrolytic metal recovery) is an electroplating process used for recovery or removal of metals from process solutions. Electrodes are placed in electrolyte solutions with direct current power applied to the cell. Electrochemical reactions occur at the electrode/electrolyte interfaces. Cations migrate to and electrons are consumed at the cathode (reduction). Anions migrate to and electrons are supplied at the anode (oxidation). Metal deposition rate is a function of the electrode area, current, solution agitation rate, solution chemistry and temperature. Metals deposited at the cathode are removed by mechanical or chemical means and are reused or recycled. Figure 3-5 presents a flow schematic for electrowinning.

Three basic approaches are used for the electrolytic recovery of metals: conventional electrowinning, high surface area and extractive methods.

*Conventional electrowinning* uses solid cathodes. The recovered metal is removed in strips or slabs and can be sold to a refiner or used in-house as an anode material. Several variations of the conventional electrowinning process are available to overcome electrode polarization and low ion diffusion rates, which reduce recovery rates in low concentration solutions. This is typically achieved by reducing the thickness of the diffusion layer through agitation of the solution or through movement of the cathode. Conventional electrolytic recovery units are usually operated on a batch basis.

*High surface area electrowinning* is most often used in continuous rinsing operations, where low concentrations are present. High surface area units extract the metal onto cathodes made of fibrous material such as carbon. Passage of a strip solution through the unit and reversal of the current regenerate the fiber cathode.

*Extractive electrowinning methods* are used to remove dissolved metals from solution, without regard to recovery. Extractive methods may include using disposable cathodes. Dummy plating, an important form of the extractive method for surface finishing, is an electrolytic treatment process in which metallic contaminants in a surface finishing solution are either plated out (low-current density electrolysis, LCD) or oxidized (high-current

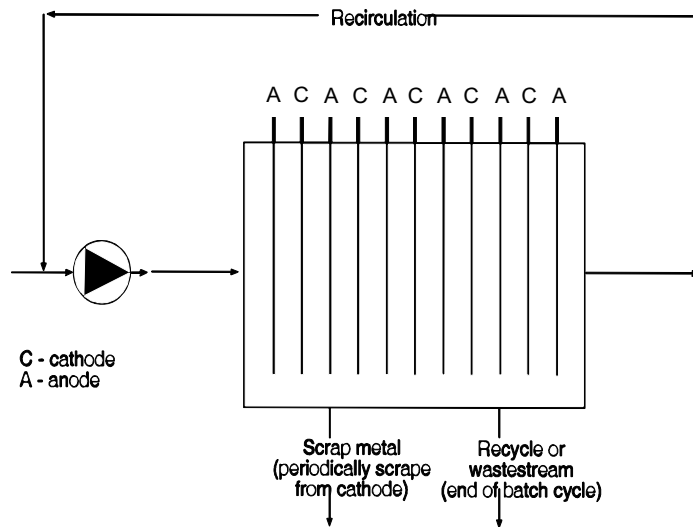

Figure 3-5. Electrowinning system.

density/high anode: cathode ratio electrolysis, HCD). LCD dummy plating uses an average current density of 5 amps per square foot (ASF). Copper and lead are removed preferentially at 2-4 ASF and zinc and iron at 6-8 ASF. Increasing the overall cathode surface area and current while maintaining the average current density can increase the rate of removal. Solution agitation will improve the overall efficiency of the process.

High-current density (HCD) dummy plating typically refers to the practice of oxidizing trivalent chromium to hexavalent chromium in chromium plating and chromic acid anodizing solutions. It has also been used to gas-off chloride as chlorine. This process requires the use of anode:cathode ratios of between 10:1 and 30:1. Lead or lead alloy anodes are typically used in the process. Current densities ranging between 100-300 ASF are used. The overall cathode and anode areas and current control the rate of conversion.

Electrowinning uses insoluble anodes in all cases except the specialized dummy plating previously described. Anode materials include graphite, lead, lead alloys, stainless steel, and coated (platinum, iridium, ruthenium oxide) titanium, tantalum, tungsten, niobium, and conductive ceramics. Anode material selection is based on anode corrosion, overvoltage characteristics, available forms and life cycle cost factors. Typical cathode materials include stainless steel, steel, porous carbon, graphite, metallized glass and plastic beads, and substrates equivalent to the metal being deposited.

### 3.5.1 Applications

Electrowinning is applied to a wide variety of surface finishing solutions. Electrolytic recovery works best in concentrated solutions. In the electroplating industry, metals most commonly recovered by electrowinning are precious metals, copper, cadmium, zinc, tin and tin /lead.

The more noble the metal in solution, the more amenable it is to electrowinning from solution. For example, with adequate agitation, solution conductivity and temperature, gold can be removed from solution down to 10 mg/L using flat-plate cathodes.

Applications include:

- Acid purification (e.g., sulfuric acid used for copper wire pickling)
- Recovery of metals from ion exchange regenerants and reverse osmosis concentrates
- Controlling metal concentrations in electroplating solution applications where the metal concentration increases over time
- Recovery of metals from spent surface finishing solutions
- Use of low-current density (LCD) dummy plating in the purification of nickel plating, nickel strikes, copper plating, cadmium plating, and trivalent chromium plating
- Use of electrolysis to oxidize concentrated cyanide solutions

LCD dummy plating can be used in both a continuous and batch mode. Continuous dummy plating is often practiced in high-build sulfamate nickel plating applications such as aerospace overhaul and repair operations and electroforming. Batch treatment is usually performed in the process tank and requires periodic down time. Continuous treatment is usually performed in a side tank, which should be sized to allow approximately 0.05 ampere-hours per

gallon of plating solution. The side tank can normally be connected into the process filtration loop.

### **3.5.2 Limitations**

Chromium is the only commonly plated metal not recoverable using electrowinning. Nickel recovery is feasible, yet requires close control of pH. Minimum practical concentration requirements vary for the specific metal to be recovered and for cathode type. Systems with flat-plate cathodes operate efficiently with metal concentrations greater than 1 to 5 g/L. For copper and tin, a concentration in the range of 2 to 10 g/L is required for homogeneous metal deposits.

Metals recovery can be difficult to perform for solutions that contain chelated or complexed metals, reducing agents, or stabilizers.

### **3.5.3 Secondary Stream(s)**

Solutions depleted by electrolytic recovery can often be treated using ion exchange to reconcentrate the ions. Plated-out metals can often be reused or sold as scrap metal.

### **3.5.4 Electrowinning Systems**

Typical system components include:

- Electrowinning tanks
- Electrodes
- Feed pump
- Ventilation system
- Rectifier, buss bars, and bussing

A variety of cell designs is available to provide a range of voltage drop, mass transfer, and specific electrode area properties. Electrolytic cells that use metal fiber cathodes can recover metals at significantly lower concentration than can flat plate cathodes. Many techniques can be used to improve the hydrodynamic conditions of the cell and force convection. These include electrolyte agitation, pumped recirculation, rotating electrodes, and fluidized beds. As the complexity of the system increases, so do capital cost and operation and maintenance costs.

### **3.6 Other Technologies**

Table 3-1 (page 6) presents a description of eight technologies with relatively limited existing surface finishing concentrated process solution applications. Note that some of these technologies, like ion exchange, are used extensively for rinse water applications.

## 4. Rinse Purification or Concentrate Recovery Technologies

Purifying and recycling process rinse water reduces water use, wastewater generation and contaminant load from influent water. Influent water contaminants must be removed in water pretreatment systems, to prevent entry into the processes. Purifying and recycling rinse water can improve process rinsing quality, thereby improving production. In some cases, it is possible to recover concentrated solutions during rinse water purification.

This section presents technology descriptions, applications and limitations, secondary stream identification, and system components and configurations for four key technologies for surface finishing rinse water purification and process solution recovery:

- Ion Exchange
- Reverse Osmosis
- Vacuum Evaporation
- Atmospheric Evaporation

Brief summaries follow for another six technologies that are either commercial, with relatively limited existing surface finishing concentrated process solution applications, or are emerging:

- Electrodeionization
- Electrodialysis
- Electrowinning
- Nanofiltration
- Polymer Filtration
- Ultrafiltration

### 4.1 Ion Exchange

Ion exchange is a chemical reaction where ions from solutions are exchanged for ions attached to chemically active functional groups on ion exchange resins. Ion exchange resins are typically classified as cation exchange resins or anion exchange resins. Cation resins usually exchange sodium or hydrogen ions for positively charged cations such as nickel, copper and sodium. Anion

resins typically exchange hydroxyl ions for negatively charged ions such as chromates, sulfates and chlorides. Cation and anion exchange resins are both produced from three-dimensional, organic polymer networks. However, they have different ionizable functional group attachments that provide different ion exchange properties. Ion exchange resins have varying ion-specific selectivities (preferences for removal).

The following chemical equilibrium equation describes a cation exchange process:

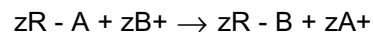

R - = Resin functional group

A<sup>+</sup> = Resin-bound cation

B<sup>+</sup> = Water phase cation

z = Number of equivalents

Ion exchange systems typically consist of columns loaded with ion exchange resin beads. Process solutions are pumped through the columns for treatment. Figure 4-1 presents a general flow schematic for ion exchange purification of rinse water.

Key features of ion exchange column systems:

- Ions are removed in a continuous flow system.
- The ion exchange resins load in the direction of flow until the entire column is loaded.
- Resins can be regenerated, whereby acidic solutions are typically used to remove metals from cation exchange resins, and caustic solutions are typically used to remove resin-bound salts. Rinse solutions are used to remove excess regeneration fluids from the columns.
- The linear flow velocity through the resin bed impacts the ion exchange rate.

The major types of ion exchange resins include:

- *Strong acid resins.* A typical strong acid resin functional group is the sulfonic acid group (SO<sub>3</sub>H).

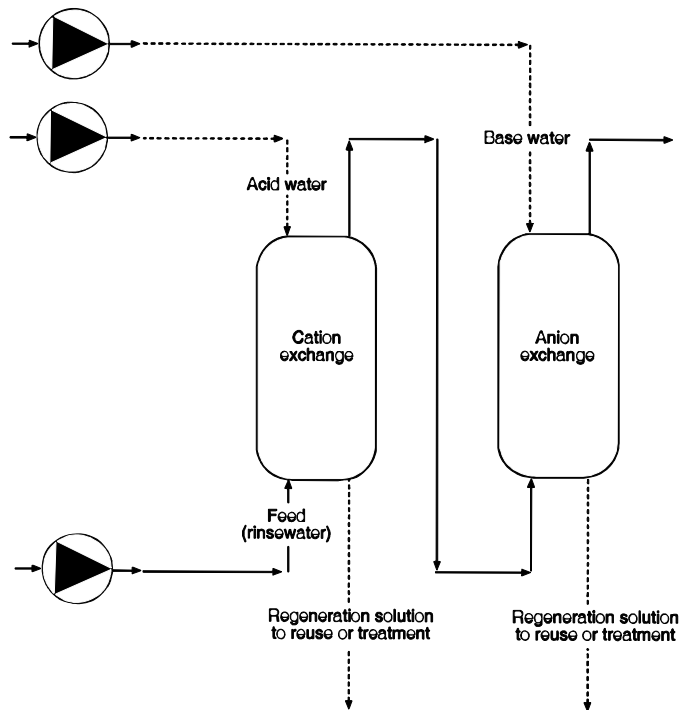

Figure 4-1. Ion exchange system.

Strong acid resins are highly ionized cation exchangers. The exchange capacity of strong acid resins is relatively constant over specific functional pH ranges.

- *Weak acid resins.* A typical weak acid resin functional group is a carboxylic acid group (COOH). Weak acid resins exhibit a much higher affinity for hydrogen ions than do strong acid resins, and can be regenerated using significantly lower quantities of regeneration reagents. Dissociation of weak acid resins is strongly influenced by solution pH. Weak acid resin capacity is influenced by pH and has limited capacity below a pH of approximately 6.0.
- *Strong base resins.* A typical strong base resin functional group is the quaternary ammonia group. Strong base resins are highly ionized anion exchangers. The exchange capacity of strong base resins is relatively constant over specific functional pH ranges.
- *Weak base resins.* Weak base resins exhibit a much higher affinity for hydroxide ions than do strong base resins and can be regenerated using significantly lower quantities of regeneration reagents. Dissociation of weak base resins is strongly influenced by solution pH; resin capacity is influenced by pH and has limited capacity above a pH of approximately 7.0.

- *Chelating resins.* Chelating resins behave similarly to weak acid cation resins but exhibit a high degree of selectivity for heavy metal cations. One common type of chelating resin is iminodiacetate chelant resin. This resin has two carboxylic acid functional groups attached to a nitrogen atom that is attached to the resin polymeric structure. The carboxylic acid groups exchange with different cations, similar to a weak acid resin. However, the nitrogen atom can also form a ligand bond with metal cations, thereby adding another cation capture mechanism. Chelating resins are particularly selective for heavier divalent cations over monovalent or trivalent cations due to the presence of two desirably spaced functional groups.

The following lists illustrate relative ion-specific selectivity preferences for common commercial ion exchange resin types. The ions on each list are ordered from highest to lowest selectivity.

*Strong acid (cation) resin selectivity:*

Barium> Lead> Strontium> Calcium> Nickel> Cadmium> Copper> Zinc> Iron> Magnesium> Manganese> Alkali metals> Hydrogen

*Strong base (anion) resin selectivity:*

Iodide> Nitrate> Bisulfite> Chloride> Cyanide> Bicarbonate> Hydroxide> Fluoride> Sulfate

*Weak acid (cation) resin selectivity:*



Copper> Lead> Iron> Zinc> Nickel> Cadmium> Calcium> Magnesium> Strontium> Barium> Alkalis

**Chelating resin selectivity (iminodiacetate):**

Copper> Mercury> Lead> Nickel> Zinc> Cadmium > Cobalt> Iron> Manganese> Calcium> Magnesium> Strontium> Barium> Alkalis

**Chelating resin selectivity (aminophosphonic):**

Lead> Copper> Zinc> Nickel> Cadmium> Cobalt > Calcium> Magnesium> Strontium> Barium> Alkalis

The exchange capacity of typical ion exchange resins can be expressed in milliequivalent per liter (meq/L = ppm of ions/equivalent weight per liter). Table 4-1 presents typical exchange capacities for common commercial ion exchange resins.

**4.1.1 Applications**

Ion exchange has been used commercially for many years in water deionization, water softening applications, and wastewater treatment applications. There are widespread applications for rinse water recovery and metals recovery in the surface finishing industry. The most common applications include recovery of copper (from acid copper solutions), nickel and precious metals from plating rinse water.

Ion exchange is an excellent technology for recovering plating chemicals from dilute rinse waters. In the typical configuration, rinse water containing a dilute concentration of plating chemicals is passed through an ion exchange column where metals are removed from the rinse water and held by the ion exchange resin. When the capacity of the unit is reached, the resin is regenerated and the metals are concentrated into a manageable volume of solution.

For conventional chemical recovery processes, systems are designed with either cation or anion beds, depending on the charge of the ionic species being recovered. After passing through the column, the treated rinse water is discharged to the sewer or undergoes subsequent treatment. In most cases, rinse water is recycled to the process. Such systems include both cation and anion columns to completely deionize the rinse water.

Drag-out recovery tanks can be combined with ion exchange to reduce the required capacity of the ion

exchange columns. Using this configuration, the drag-out tank(s) are followed by an overflow rinse that feeds an ion exchange column. In operation, the drag-out tanks return the bulk of the plating chemicals to the plating bath and an ion exchange column captures only the residual chemical load. This reduces the ion exchange system size requirement.

**4.1.2 Limitations**

Common limitations for ion exchange:

- Ion exchange may become impractical for use with total dissolved solids concentrations above 500 ppm, due to the need for frequent regeneration.
- Resins have different effective pH ranges. For example, iminodiacetate chelating resin works best in a slightly acidic range; selectivity is lower at higher pH and below a pH of approximately 2.0.
- Oxidants, solvents, organics, oil and grease can degrade resins.
- Suspended solids can clog resin columns.

**4.1.3 Secondary Stream(s)**

Regenerant chemicals can be selected to optimize the products derived from the regeneration of ion exchange resins. Chemicals are selected to produce salts that can be directly recovered in the treatment process. Metals are recovered via electrowinning and salts are recovered off-site.

Depending on the chemical product specification of the recovery process, the regenerant solution can be returned directly to the plating tank for reuse, further processed, or the metals recovered by another technology, such as electrowinning. The most common applications of this technology are in the recovery of copper, nickel and precious metals.

Countercurrent regeneration mechanisms can result in significantly lower chemical use for regeneration as the regenerated zone is always maintained in a “clean” condition. Co-current regeneration requires higher chemical use and/or results in lower initial water quality as the “regenerated zone” is left in a semi-contaminated state following regeneration.

**4.1.4 Ion Exchange Systems**

Typical system components include:

- Ion exchange columns with resin
- Process pumps, piping and valves
- Regeneration tanks, pumps and piping

**Table 4-1.** Typical Ion Exchange Capacities for General Resin Types (in milliequivalents per liter, meq/L)

Resin Type	Exchange Capacity (meq/L)
Strong Acid (Cation)	1800
Weak Acid (Cation)	4000
Strong Base (Anion)	1400
Weak Base (Anion)	1600
Chelating (Sodium form)	1000

- Regeneration chemicals and chemical mix systems
- Prefilters (to remove solids and organics)
- Process controls (for automated or semi-automated regeneration cycles)

Depending on the application, various combinations of anion, cation, and mixed-bed (anion/cation) resins may be used.

## 4.2 Reverse Osmosis

Reverse osmosis (RO) is a membrane separation process that separates dissolved salts from water using a hydrostatic pressure gradient across a membrane. An applied hydrostatic pressure exceeding the osmotic pressure of the feed solution causes water to flow through the membrane from the more concentrated feed solution into the relatively low-concentration permeate solution. This flow is the reverse of natural osmotic diffusion where water would flow from the dilute phase into the concentrated phase. Dissolved solids are rejected by the membrane surface. Many multi-charged ions can be rejected at rates exceeding 99%. Single-charged ions typically have rejection rates in the range of 90-96%.

Three important parameters impact the performance of the RO process:

- Recovery, defined as the percentage of the feed that is converted to permeate
- Permeate flux, or the rate at which the permeate passes through the membrane per unit of membrane surface area
- Rejection, which describes the ability of the membrane to restrict the passage of specific dissolved salts into the permeate

The flux is determined by the hydrodynamic permeability and the net pressure differential (hydrostatic pressure difference between feed and permeate minus the osmotic pressure difference) across the membrane. Higher pressure differentials generally result in higher flux rates. The applied pressure is generally between 400 and 800 PSI. In some specialized applications, pressures greater than 1000 PSI are used. Permeate flux decreases over time as an RO system is operated and the membranes become fouled. Periodic cleaning of the membrane restores flux. Cleaning should be initiated when a *decrease* of 10-15% permeate flow, an *increase* of 10-15% normalized differential pressure or a *decrease* of 1-2% rejection is observed.

Rejection efficiency is specific to each component, and is a function of concentration gradient across the membrane. As the concentration gradient increases, the rejection efficiency decreases. The leakage of various salts is a function of the molecule size, ion radius, ion charge and the interacting forces between the solute and the solvent. The rejection of organic molecules is mainly a function of the molecular weight and size of the molecules.

### 4.2.1 Applications

Reverse osmosis is used in the surface finishing industry for purifying rinse water and for recovery of chemicals from rinse waters. It has also been used to purify raw water for the generation of high-quality deionized water in rinsing and plating solutions. Figure 4-2 presents a reverse osmosis flow schematic for rinse water applications.

Reverse osmosis applications involving the separation of plating chemical drag-out from rinse water have been applied mainly to nickel plating operations (sulfamate, fluoborate, Watts and bright nickel). Other common applications include copper (acid and cyanide) and acid zinc. Recently, RO has been applied successfully to

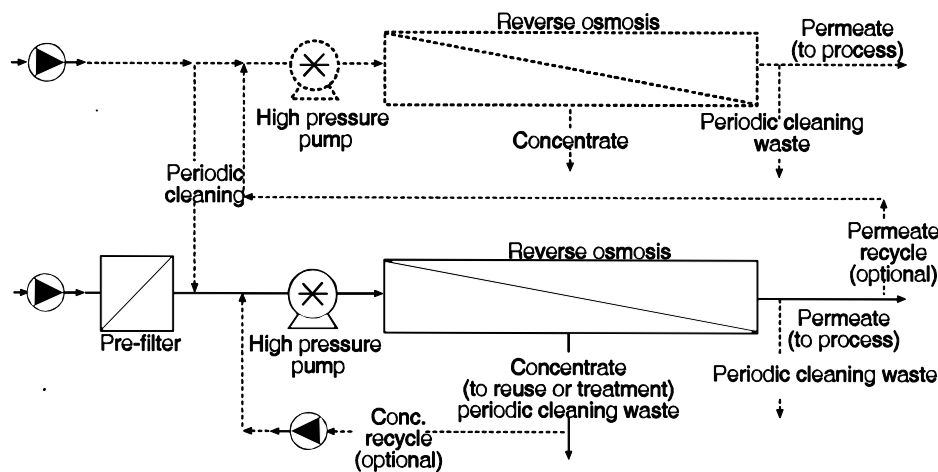

Figure 4-2. Reverse osmosis system.

chromate rinse water. In the typical configuration, the RO unit is operated in a loop with the first rinse following plating. The concentrate stream is recycled to the plating bath and the permeate stream is recycled to the final rinse.

Reverse osmosis is commonly used for water treatment (with and without ion exchange) applications requiring production of high-quality water from high total dissolved solids (TDS) sources. Large-scale wastewater recycling is evolving as an important application for RO in the surface finishing industry. Microfiltration, ultrafiltration, nanofiltration and reverse osmosis are often used in series to provide pretreatment for a range of filtration size separation needs and to maximize performance of the total system.

Specialty membranes are available that offer an extended pH range (1-13) and greater resistance to oxidizing chemicals.

#### **4.2.2 Limitations**

Membrane performance of all polymer-based membranes decreases over time. Permeate flow (flux) and membrane rejection performance are reduced. RO membranes are susceptible to fouling by organics, water hardness, and suspended solids in the feed stream or materials that precipitate during processing. Installing prefilters can control solids in the feed stream. Changing operational parameters, such as pH, inhibits precipitation. Oxidizing chemicals like peroxide, chlorine and chromic acid can also damage polymer membranes. Acid and alkaline solutions with concentrations greater than .025 molar can also deteriorate membranes.

In most applications, the feed solution will have significant osmotic pressure that must be overcome by the hydrostatic pressure. This pressure requirement limits the practical application of this technology to solutions with total dissolved solids concentrations below approximately 5000 ppm (with the exception of disc tube applications).

Specific ionic levels in the concentrate must be kept below the solubility product points to prevent precipitation and fouling. Ionic species differ with respect to rejection percentage. Some ions such as borates exhibit relatively poor rejection rates for conventional membranes.

#### **4.2.3 Secondary Stream(s)**

Reverse osmosis concentrate streams can be recycled to the process, sent to reclamation, or managed as a concentrated waste. Acid, EDTA and alkaline cleaning solutions are used to clean RO membranes, depending on the nature of the foulant. These cleaning solutions are residual wastes that need to be managed.

#### **4.2.4 Reverse Osmosis Systems**

Typical system components include:

- Pressure vessel(s) with application-specific membrane modules

- Applicable feed, pressure, and recycle pumps, valves, and piping
- Application-specific flow, level, temperature, conductivity, and pressure instrumentation and controls
- Feed and discharge tanks and systems
- Application-specific pretreatment systems (e.g., cartridge filtration, carbon, pH adjustment, microfiltration, ultrafiltration, nanofiltration)

Selection of the RO membrane type depends on both the application and the plating bath chemistry. RO membranes are most common in spiral-wound or hollow fiber configurations. More advanced systems use a disc tube modular configuration.

Many systems are designed with two or more RO stages. This design feature will allow the concentrate stream from the first stage to be passed through a second stage to further concentrate the chemicals. The practical limit for plating chemical concentration is up to 15 to 20 g/L (or lower if compounds are near their limit for precipitation). In some cases, insufficient surface evaporation in the plating tank limits direct reuse of the RO concentrate stream. An evaporator can be used to further concentrate the solution or to supplement bath evaporation.

### **4.3 Vacuum Evaporation**

Vacuum evaporators distill water from process solutions at reduced temperatures compared with atmospheric evaporation. Vacuum evaporators work without the need for an air stream feed or discharge. Vacuum evaporators produce a distillate and a concentrate. The distilled water is typically condensed and recovered as high-quality rinse water. The concentrate contains process chemistry to return to the appropriate process bath. Figure 4-3 provides a process flow schematic for vacuum evaporation.

#### **4.3.1 Applications**

Vacuum evaporators are used for concentrating and recovering process solutions and rinses, and are particularly well-suited for specific applications where:

- Air pollution control is a potential problem (Air discharge is typically not an issue for vacuum evaporation).
- Relatively low evaporation temperatures are needed to avoid problems with temperature-sensitive products.
- Alkaline cyanide solutions that build up carbonates are present (atmospheric evaporators would aerate the solution and accelerate the buildup of carbonates).
- Process solutions are sensitive to air oxidation.

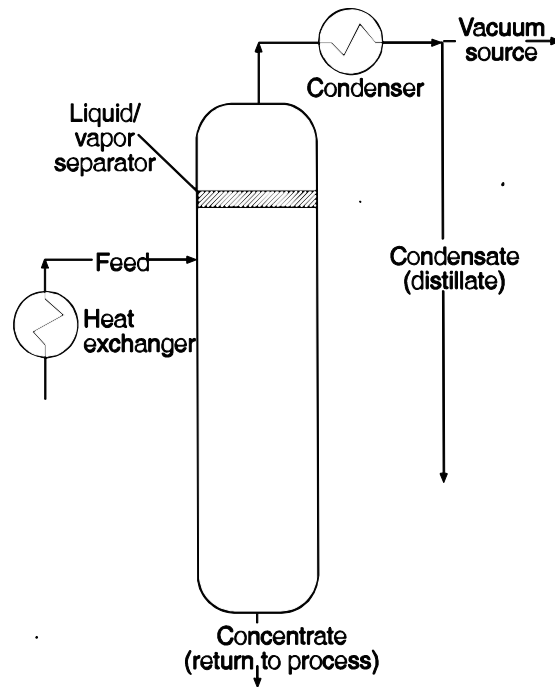

Figure 4-3. Vacuum evaporation system.

- Energy costs are high for atmospheric evaporation.

### 4.3.2 Limitations

Limitations associated with vacuum evaporation systems include relatively high capital cost, and application-specific potential for fouling and separation limitations.

### 4.3.3 Secondary Stream(s)

Vacuum evaporators produce a high-quality condensate that can be reused as a process rinse and a concentrate that contains the process chemistry to be reused, recycled, or managed as a waste. Potential secondary waste streams could be generated if there are periodic system cleanout requirements to remove fouling compounds.

### 4.3.4 Vacuum Evaporator Systems

Several types of vacuum evaporators are used in the surface finishing industry: rising film, flash-type, and submerged tube. Generally, each consists of a boiling chamber under a vacuum, a liquid/vapor separator and a condensing system. Site-specific conditions and the mode of operation influence the system selection.

Energy for evaporation can be supplied either thermally or mechanically. Two techniques have been applied successfully to reduce the steam or electricity demand for evaporation, multiple-effect evaporation and

mechanical vapor recompression. Both involve reusing the heat value contained in the vapor from the separator.

Multiple-effect evaporators are vacuum evaporators in series with different boiling points, operated at different vacuum levels. The solution to be concentrated is fed into the boiling chamber of the first effect and external heat is introduced to volatilize the water. The water vapor is then condensed at a different vacuum level and the energy is used to heat the subsequent vacuum chamber. Energy is used several times in multiple stages. Multiple-effect evaporators are practical for larger scale applications and those in which high-boiling point elevations make vapor compression ineffective. These systems can be configured so that a final effect can create crystal solids. Increasing the number of effects increases energy efficiency, but also increases the capital cost of the system. Optimization involves balancing capital versus operating costs.

The second technique is the use of a mechanical compressor. These evaporators are similar to single effect units, except that the vapor released from the boiling solution is compressed in a mechanical or thermal compressor. This compressed water vapor condenses, yielding latent heat of vaporization, which is used to evaporate more water from the concentrated liquid. These types of evaporators can concentrate to about 50% dissolved solids, and evaporative capacities range from 200-2400 liters (50-600 gallons) per hour. Vapor

recompression evaporators are the highest-capital-cost evaporators, but are the most energy efficient.

#### 4.4 Atmospheric Evaporation

Atmospheric evaporators use an air stream to strip water from a process solution. The process solution is pumped through the evaporator where it contacts the air stream blown through the evaporator. The humidified air stream is discharged to the atmosphere. The evaporation chamber is usually filled with a packing material to increase the air-to-water evaporation surface. Depending on the process solution and air conditions, heating the process solution and/or the air stream may be necessary to achieve sufficient evaporation.

##### 4.4.1 Applications

Atmospheric evaporators are relatively basic, uncomplicated low-capital-cost systems. Atmospheric evaporators are used in conjunction with plating bath rinses to recover process chemistry removed by drag-out. Two basic approaches where atmospheric evaporators are used to help achieve chemical recovery:

- The solution from a heated plating tank is fed to and concentrated by an atmospheric evaporator and returned to the plating tank. This increases the quantity of recovery rinse water that can be transferred to the plating tank.
- The recovery rinse water is fed to the evaporator, concentrated, and returned to the plating tank.

Figure 4-4 illustrates a process flow schematic for atmospheric evaporation. One application particularly well-suited for atmospheric evaporation is drag-out recovery for hard chrome baths, where heat is supplied to the evaporator by the hard chrome bath. This achieves drag-out recovery and removes excess heat from a high-amperage plating bath.

##### 4.4.2 Limitations

Atmospheric evaporation systems have several limitations:

- When the feed process stream and/or air stream needs to be heated, atmospheric evaporators typically have a high energy use.
- The discharge air stream may require treatment to avoid discharge of hazardous substances.

- In some applications, there is a risk of overconcentration and fouling the evaporator due to salting-out.
- Surfactants or wetters used in plating baths can cause foaming problems in the evaporator.
- Some bath constituents may be susceptible to heat degradation or may be oxidized by exposure to air.
- Aeration of the process solutions can cause carbonates to build up.
- Recovery results vary depending on changing process conditions and air stream conditions.

##### 4.4.3 Secondary Stream(s)

Humidified air streams are vented from atmospheric evaporators. These streams may present air emission problems.

##### 4.4.4 Atmospheric Evaporation Systems

Common atmospheric evaporator system components include:

- Process solution feed pump
- Blower to draw air into and move through the evaporator with sufficient exit velocity
- Heat source
- Evaporation chamber in which the water and air can be mixed
- Mist eliminator to remove any entrained liquid from the exit air stream

Typical commercial units have evaporation rates of 10 to 30 gph, depending on the size of the unit and operating conditions (e.g., solution temperature). For larger applications, multiple atmospheric evaporators are used in parallel.

#### 4.5 Other Technologies

Table 4-2 presents comments for six technologies that are commercial technologies with relatively limited surface finishing rinse applications, or that are emerging technologies:

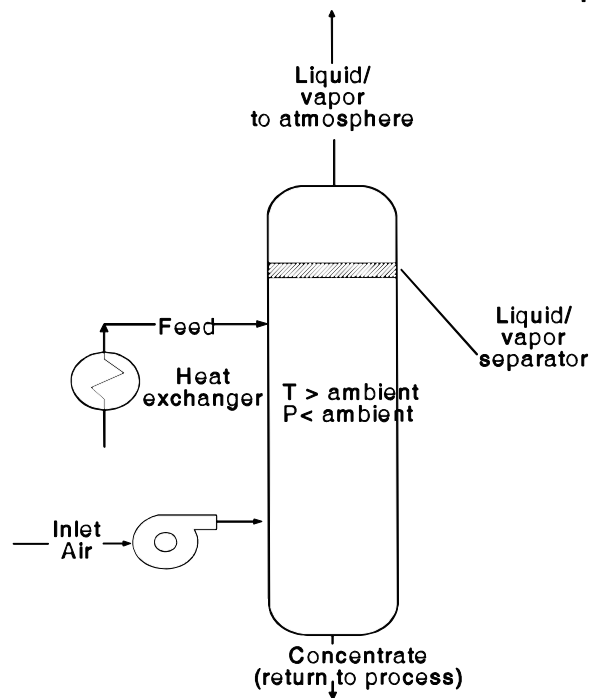

Figure 4-4. Atmospheric evaporation system.

Table 4-2. Technologies for Surface Finishing Rinse Applications

Technology	Description	Status	Applications and Limitations
Electrodeionization	Ions are removed using conventional ion exchange resins. An electric current is used to continuously regenerate the resin (instead of regeneration chemicals).	Commercial technology; limited surface finishing applications.	Effective for relatively high-purity water purification/recovery applications, including polishing treatment of reverse osmosis permeate to meet process rinse purity requirements.
Electrodialysis	Anions and cations are removed from solutions with an applied electric field in cells with alternating anion- and cation-permeable membranes.	Commercial technology; limited surface finishing applications.	Electrodialysis has been used in the surface finishing industry to recover nickel salts from rinse water.
Electrowinning	Electrodes are placed in solutions, and direct current power is applied. Electrochemical reactions occur at the electrode/electrolyte interfaces. Cations migrate to, and electrons are consumed at the cathode (reduction). Anions migrate to, and electrons are supplied at the anode (oxidation).	Commercial technology; widely used for removal of metals from surface finishing concentrated solution; limited applications for rinses.	Electrolytic cells that use a metal fiber cathode have demonstrated the ability to remove less-noble metals, such as copper and cadmium, from recirculated rinses to concentrations in the range of 10 to 50 mg/L. High-surface-area units are used to recover metals from cyanide-based plating process rinses (e.g., cadmium, copper, zinc, and brass). These units remove metal ions to low concentrations and also oxidize the cyanide in the rinse water.
Nanofiltration	Membrane filtration that operates at larger pore sizes (rejects molecules larger than 0.001 to 0.08 microns), and lower typical pressure (50 to 400 psi) than reverse osmosis. Preferentially rejects some ions and passes others.	Commercial technology; limited surface finishing applications.	Recovery of metals and water recycle for rinse waters.
Polymer Filtration	Chelating, water soluble polymers selectively bind target metals in aqueous streams.	Emerging	Selective metals removal from rinse waters.
Ultrafiltration	Membrane filtration process that passes ions and rejects macromolecules (0.005 to 0.1 micron).	Commercial technology; limited surface finishing applications.	Removal of oils, colloidal silica, particles, and proteins from rinse waters for reclamation.

## 5. Alternative Surface Finishing Processes and Coatings

Process substitution is a form of process optimization, where environmentally cleaner process alternatives replace existing processes in part or in whole. Process substitution, however, will not automatically result in cleaner manufacturing. In assessing alternative processes, the first step is to review existing processes for opportunities to optimize those processes. Adaptation of new processes is generally desirable when implemented on a progressive basis, but can often fail when implemented without careful planning basis. Process change can be complicated and deserves careful evaluation. New processes may present unexpected problems that are relatively difficult to manage compared to known problems with existing processes.

Successful process substitution requires well-defined goals. This involves identifying the drivers which impact the manufacturing process. Too often, process substitution is begun prematurely without a clear understanding of the drivers and constraints.

One common misconception is that toxic use reduction (TUR) and toxic waste reduction (TWR) are synonymous. TUR may require process change; whereas, TWR often favors process optimization. Toxic use reduction has a primary goal of reducing the amount of hazardous raw materials used. This goal can be accomplished by a variety of methods that follow substitution, reuse and recycling. Toxic waste reduction seeks to reduce hazardous waste generation by optimizing the existing process, rather than a wholesale process substitution. Both techniques can result in more efficient processes by incorporating recovery and/or recycling options.

Another common misconception in process substitution is that substitute technologies must embody all of the finished surface properties of the existing finished surface. Alternatives should possess the properties critical to that application. The application should be assessed to determine critical and non-critical properties. The result will be a wider range of possible alternatives.

A third common misconception is that alternatives must be universal. There are rarely any universal substitutes. Instead, several alternatives may be required to satisfy a range of applications.

### 5.1 Process Engineering and Re-engineering

Process engineering and re-engineering costs and success can be impacted by a variety of factors, including chronology. Mature processes are often significantly constrained by product specifications and the expected life of the process. A process that will be phased out within a few years will undoubtedly receive little new investment for engineering or capital. Many mature processes are also constrained by risk factors. A failure of a new coating in a jet engine can result in human tragedy. Process changes can require significant testing and associated costs.

How changes impact overall product and process flow is also an important consideration. Manufacturing flow is becoming more cellular and this results in the addition of multiple smaller-scale wet processes to support the manufacturing cells. Key questions to consider for overall impacts:

- How will new process(es) affect manufacturing flow?
- How will the new process(es) fit into the overall facility?

### 5.2 Surface Finishing Properties

Finished surface properties and variability with different process factors are important to evaluate to consider substitute processes. Decorative and functional properties are affected by key process parameters such as solution concentration, bath additives, bath temperature, and current density. Careful consideration of these parameters in the context of process substitution or optimization is key to successful process change. Coating adhesion, pre-processing requirements, and plating characteristics over a range of operating parameters all can vary for a process substitution.

Questions to consider for potential substitutions include:

- How will processing times be affected?
- Are different pre-processing steps required?
- How will the pre-processing treatment steps affect the substrate?

- Will additional procedures, such as grinding or coating, be required to achieve the final surface requirements?

### 5.3 Surface Engineering

Surface finishing is an integrated system. Surface engineering that considers the entire product manufacturing cycle will result in much greater choices and efficiency. Successful process change is the product of a logical evaluation of not only the immediate process, but also how this process fits into the scheme of the entire manufacturing picture.

### 5.4 Surface Finishing Costs

Overall costs to produce a finished surface determine the efficacy of a process substitution. Coatings are generally applied to reduce net product cost and/or enhance product properties. Copper-plated aluminum may be used instead of solid copper to reduce cost or weight. In many applications, both the substrate and the coating are critical to the application. The substrate provides material strength or other properties, while the coating provides corrosion resistance or cosmetic appeal. Polished stainless steel is often used in place of chromium-plated trim. Chromium-plated plastic may be a viable lower-cost alternative to stainless steel.

### 5.5 Alternative Coatings and Processes

There is a wide range of alternative processes and coatings available. Some are common surface finishing techniques in which the range of application is being expanded by subtle change. Others are newer solutions that have applicability in specific situations, such as vacuum and thermal spray techniques. Alternative coatings and processes include:

- 1) Alternative Electroplated and Electroless Coatings
- 2) Anodizing
- 3) Organic Coatings
- 4) Vapor Deposition
- 5) Thermal Spray
- 6) Hardfacing
- 7) Porcelain Enameling
- 8) Metal Cladding and Bonding
- 9) Alternative Substrates
- 10) Alternative Substrate Treatments
- 11) Alternative Surface Preparation
- 12) Alternative Stripping Processes

- 13) Alternative Pickling and Descaling
- 14) Alternative Etching
- 15) Alternative Cleaning
- 16) Forming and Fabrication

#### 5.5.1 Alternative Electroplated and Electroless Coatings

Much process change is focused on alloy plating techniques. For some applications, alloy plating can replace chromium, cadmium and other metals. These solutions require more attentive control and are typically more difficult to recover from rinse streams, primarily due to the selectivity of recovery processes for specific atomic species. The control and recovery factors, if not properly handled, can lead to increases in labor, processing times and product defects.

Alloy plating processes include nickel/tungsten/boron, tin/nickel, tin/zinc, zinc/nickel, copper/tin/zinc, and zinc/cobalt alloys. Nickel composite processes are important in applications requiring lubricity and/or wear resistance. Aluminum electroplating has replaced cadmium in some applications. Zinc and cadmium (cyanide and non-cyanide) are the most important sacrificial coatings available. Copper (cyanide and non-cyanide) plating is ubiquitous. Trivalent chromium has replaced hexavalent chromium in many decorative plating applications and is becoming more important in functional applications. Nonchromate conversion coatings are evolving rapidly, and in some cases offer better performance than chromates. Silver (cyanide and non-cyanide), tin and lead-free tin-alloy plating alternatives have also been developed and are gaining acceptance in some applications. Electroless alternatives include nickel, copper, gold, silver, cobalt, platinum, palladium, ruthenium, and palladium, ruthenium, rhodium, and iridium alloys. Hot dipping processes include zinc, aluminum, tin and lead. Mechanical plating processes include zinc, cadmium, zinc/cadmium, tin/cadmium, tin, copper, and lead.

#### 5.5.2 Anodizing

For many years, sulfuric acid anodizing and chromic acid anodizing have been used widely in industry. One of the main benefits of chromic acid anodizing is that residue in lap joints or blind holes is not corrosive to the part. However, in this age of strict specifications, the staining these residues cause leads to rejection on a cosmetic basis. In addition, the residue represents lost material valuable to the process. Coupled with risk from its health hazards, chromic acid anodizing is declining. In many applications it can be replaced by sulfuric/boric acid anodizing.

Other alternative anodizing processes include sulfuric, sulfuric/oxalic, sulfuric/boric, phosphoric, oxalic, sulfamic ( $\text{NH}_2\text{SO}_2\text{OH}$ ), malonic ( $\text{CH}_2(\text{COOH})_2$ ), and mellitic



(C<sub>6</sub>(COOH)<sub>6</sub>) chemistries and numerous variations thereof with special additives.

### 5.5.3 Organic Coatings

Organic coatings have always been an alternative to electroplating, and recent formulations and application methods have increased the substitution of organic coatings for traditional electroplating applications. Higher-efficiency coating techniques, such as powder coating and electrocoating, have made organic coatings very attractive. In addition, many solvent systems that eliminate the traditional VOCs are appearing. Some drawbacks occur with two-part epoxy finishes, due to their limited application times, ("pot life") after mixing. Another difficulty that can arise, particularly with thermal cure coatings, is a loss of viscosity prior to final cure. This effect can result in non-uniform coatings. Sometimes, partial cure can reduce this effect. Many of the more efficient coating techniques are capital-intensive for equipment. Since newer coatings are quite expensive, it is easier to justify equipment on the basis of savings these improvements yield. Organic finishing can produce bright, metallic-looking coatings, as well as a variety of colors and textures.

Coating techniques include spray coating, powder coating, electrocoating, autodeposition and dip processes. Organic coatings are made up of polymers or binders, solvents, pigments and additives. Polymers or binders include natural oils, alkyds, polyesters, aminoplast resins, phenolic resins, polyurethane resins, epoxy resins, silicon resins, acrylic resins, vinyl resins, cellulose and fluorocarbons. Pigments are classified as colored, white, metallic and functional. Solvents are classified as active solvents, dilutants and thinners. Additives include surfactants, colloids, thickeners, biocides, fungicides, freeze/thaw stabilizers, coalescing agents, defoamers, plasticizers, flattening agents, flow modifiers, stabilizers, catalysts and anti-skinning agents. Organic coatings require careful screening to optimize life cycle cost factors.

### 5.5.4 Vapor Deposition

Vapor deposition offers finishing alternatives in some specific and ever-expanding applications. The equipment used is relatively expensive, can require high-level operators and is sensitive to contamination. Vapor deposition is, generally, a high-vacuum process. The systems are sensitive to humidity, often require controlled environments and are vented with dry nitrogen or compressed air. Some cycle times are quite short, while others can take several hours.

In a typical vapor deposition system, two or more stages of vacuum pumping are required (rough and high vacuum). Mechanical roughing pumps can achieve pressures of 10-100 to millitorr (760 torr = atmospheric pressure). High vacuum pumps can achieve pressures in the range of 10<sup>-5</sup>-10<sup>-8</sup> torr. These systems operate by isolating the vacuum chamber from the pumps, enabling the parts to be handled without complete system shutdown. A typical operating cycle involves set-up, rough pumping, high-

vacuum pumping, coating, venting and part removal. Cycle times can be as short as a few minutes or may require several hours. Internal systems to coat the parts vary depending on the coating material and performance requirements. There are three basic types of vapor deposition systems: chemical vapor deposition, physical vapor deposition, and ion vapor deposition.

Chemical vapor deposition (CVD) is a heat-activated process that relies on the reaction of gaseous chemical compounds with heated and suitably prepared substrates. The CVD process can produce a variety of high-density, high-strength, and high-purity coatings. The process has exceptional throwing power, and complex components can be coated successfully. Most materials readily electroplated are not suitable for CVD because these metals are not normally available as CVD-compatible halide salts.

In CVD, an inert gas is bled into the system after pump-down, to a few torr of pressure. A high voltage is applied to the gas to create a reactive plasma. Depending on the material used for coating, it may be evaporated directly and then ionized in the plasma, or ions may combine with a second gas (oxygen or nitrogen, for example) and molecules will cool and crystallize upon striking the part surface. The compound formation reaction usually occurs in the plasma. Plasmas are very energetic, and care must be exercised to prevent overheating the parts. Typical coatings include refractory compounds and refractory metals.

Physical vapor deposition (PVD) uses similar equipment and operating procedures. PVD describes a broad class of vacuum coating processes, wherein material is physically emitted from a source by evaporation or sputtering, transmitted through a vacuum or partial vacuum by the energy of the vapor particles, and condensed as a film on a substrate. Chemical compounds are deposited by selecting an equivalent source or by reacting the vapor particles with an appropriate gas. Three primary characteristics of all PVD processes are: source-generated coating emissions, vapor transport through a vacuum, and condensation on a substrate.

The PVD process is generally limited to thinner coatings of 1-200 microns. Fixturing is critical because the process is "line-of-sight." Stationary, rotary and rotary with planetary motion fixtures are used to produce uniform coatings on complex parts. The process is capable of producing coatings with extraordinary decorative and functional properties.

Ion vapor deposition (IVD) was originally developed as an ion plating process for aluminum. The properties of IVD aluminum coatings are nearly identical to aluminum. The IVD process takes place in an evacuated chamber where an inert gas is added to raise the pressure of the chamber. The gas (typically argon) becomes ionized when a high negative potential is applied to the parts to be coated. The

positively charged ions bombard the negatively charged parts and provide final cleaning. Aluminum or other metals are melted and vaporized in the chamber, and some metal vapor is ionized, coating the parts. The IVD process produces dense, highly adherent and uniform coatings over complex parts. Hydrogen embrittlement is not a factor. IVD eliminates solid-metal embrittlement of titanium and does not reduce the fatigue strength of aluminum.

Other more specialized vapor deposition processes are vacuum metallizing and sputtering. Vacuum metallizing consists of evaporating a metal or metal compound at high temperature in an evacuated chamber. The vapor condenses on a substrate in the chamber, at a relatively low temperature. Vacuum metallized coatings are typically very thin, 0.2-20 microinches. Decorative products are typically coated with protective organic topcoats. In principle, virtually all metal and metal compounds can be deposited as coatings. In practice, the process has been generally limited to aluminum, selenium, cadmium, silicon monoxide, silver, copper, gold, chromium, nickel-chromium, palladium, titanium and magnesium fluoride.

Sputtering is a specialized PVD process. Virtually all metals and compounds can be sputter-coated. This technique generates an energetic particle that strikes a target of the coating material, ejecting a molecule that strikes and cools on the part. Sputtering is very much a "line-of-sight" process and has difficulty coating surfaces perpendicular to the target plane. Coatings are generally thin (angstroms to microns), although thicknesses greater than 25 microns are possible. A variety of PVD processes exist, including:

- Diode and triode sputtering
- Planar and cylindrical magnetron sputtering
- Direct current (DC) and radio frequency (RF) sputtering
- Electron beam evaporation
- Arc evaporation

### **5.5.5 Thermal Spray**

Thermal spray is a process that deposits a molten and semi-molten matrix, including metals, metal alloys and ceramics on substrate materials. The process does not normally change the mechanical properties of the substrate. Spray materials can be in the form of rod, wire, cord or powders. Materials are heated to a molten or semi-molten state and then atomized or projected onto the target substrate. Heating is accomplished by a variety of means. As sprayed particles strike the substrate, they flatten and form thin platelets.

Coating techniques include flame spray, high-velocity oxy/fuel (HVOF), electric arc, plasma spray, and detonation gun. A wide range of coating compositions is possible with

thermal spray. Substrate heating is normally minimal. Surface preparation is usually limited to cleaning and roughening. Masking and fixturing are important for effective coating. Fixtures become coated during the process and will require frequent stripping, using strong acids to maintain the fixtures. Thermal spray is a line-of-sight process and coating of complex components can be difficult. Automation of the process with robots or specialized machinery is almost always required for a quality coating. Post-coating finishing, such as grinding, is usually required to obtain desired surface finish because the as-sprayed surface finish is often rough.

### **5.5.6 Hardfacing**

Hardfacing produces a buildup of material in specific areas to improve wear resistance or to reclaim worn parts. Mechanical finishing techniques such as grinding, polishing and lapping may be required to achieve the desired work surface. Hardfacing materials are generally applied by a variety of welding methods. Very thick layers can be built up with manual or automated equipment. Thermal spray and hardfacing coatings include tungsten carbide, high chromium irons, martensitic alloy irons, austenitic alloy irons, martensitic, semi-austenitic and pearlitic steels, chromium-tungsten alloys, chromium-molybdenum alloys, nickel-chromium alloys, chromium-cobalt-tungsten alloys, nickel-based alloys, and copper-based alloys.

### **5.5.7 Porcelain Enameling**

Porcelain enamels are highly durable, alkaliborosilicate glass coatings bonded by fusion to a variety of metal substrates at temperatures above 800°F. Porcelain enamels differ from other ceramics by their predominantly vitreous nature. Porcelain enamels have good chemical resistance, good corrosion protection, good heat resistance, reasonably good abrasion resistance and good decorative properties. Porcelain enameling is commonly applied to food processing equipment, cooking and serving utensils, jet engine components, induction heating coils, transformer cases, mufflers, home appliances, and architectural materials.

### **5.5.8 Metal Cladding and Bonding**

Metal cladding and bonding applications include stainless steel (SS) to copper and aluminum cookware, titanium and SS to copper and aluminum buss bars, electroplated plastic to aluminum and steel automotive components.

## **5.6 Alternative Substrates**

Alternative substrates can replace many coatings. Stainless steel is commonly substituted for chromium-plated steel. Copper replaces copper-plated aluminum. Anodized aluminum replaces chromium-plated steel in some applications. As the environmental costs of manufacturing processes are considered in overall product cost, more-expensive materials can often be justified.

Alternative substrates include stainless steel, copper and copper alloys, aluminum and magnesium, titanium,

tungsten and molybdenum, superalloys, plastics, composites, and powdered metals.

### **5.6.1 Alternative Substrate Treatments**

Alternative substrate treatments can be used to extend the application range of coated and uncoated substrates. Many substrate treatments are available including vacuum impregnation, heat treatment, ion implantation, laser hardening, carburizing, electron-beam hardening, nitriding, flame hardening, carbonitriding, boronizing, chromizing, induction hardening and high-frequency resistance hardening. With the exception of vacuum impregnation these treatments usually convert the surface structure of the metal substrate by the addition of small amounts of various elements at elevated temperatures. The crystal structure of the surface is altered and the new surface provides additional hardness, wear resistance or toughness, depending on the specific treatment used. These treatments often allow the substrate to function with little additional surface treatment, thereby reducing the plating or surface finishing steps required.

## **5.7 Alternative Surface Preparation**

Many alternative surface preparations can be used to extend the application range of substrates or to complement treatment and coating processes. Surface preparation, prior to plating and finishing, is also an important surface finishing step from a pollution prevention standpoint. First, these techniques remove loose metal chips and also deburr parts. If left on the part, burrs can dissolve preferentially in many of the pretreatment solutions, adding to metal loading. They also alter the local current density and can lead to additional rejects. Finally, these surface preparations can impact compressive stresses on the part, which improve fatigue strength. This can improve plating adhesion and lengthen the service life of the part. Alternative surface preparations include chemical polishing and bright dipping, electropolishing, mass finishing, abrasive flow machining, abrasive blasting (dry and wet blasting), shot peening, mass finishing, and thermal deburring and deflashing.

### **5.7.1 Alternative Stripping Processes**

Stripping process alternatives are usually focused around the substitution of non-maintainable strips for maintainable strips. Many of the non-maintainable strippers are heavily chelated to improve their useful processing capacity. Chelating chemicals bind metals to prevent immersion deposition and smut formation, and separation of these metals to extend bath life can be difficult. In addition, these materials are difficult to treat for waste. Maintainable strips are often more predictable, because some metal loading is maintained in the solution. This constant loading removes the highs and lows of processing rates related to low or high dissolved metal concentrations.

Abrasive stripping alternatives are normally applied to soft organic coatings and are not generally applicable to inorganic coatings. Chemical strippers used on organic coatings create considerable waste volumes. The

strippers cause swelling of the coating to destroy the surface bond. The strippers are often hazardous, while the cured coating is not necessarily. Abrasive blasting or water jet blasting can efficiently remove these coatings, generate less waste (often non-hazardous), and can be configured with materials that do not abrade the part surface.

### **5.7.2 Alternative Pickling and Descaling**

There is a variety of alternative pickling and descaling processes, most of which are acid-based. Alkaline processes are normally electrolytic and have historically contained cyanide. Non-cyanide alkaline descalers are heavily chelated and can cause wastewater treatment problems. Chromic acid is normally used for nonferrous alloys. Nonchromic alternatives almost always contain nitric acid, and  $\text{NO}_x$  is becoming an increasing difficult environmental control problem. Acid salts are commonly substituted for mineral acids, and ammonium bifluoride is substituted for HF to minimize safety concerns. Ammonia, however, can cause wastewater treatment problems. Potassium permanganate is used for descaling wire and other steel products, and molten salt descaling is used for a variety of applications.

### **5.7.3 Alternative Etching**

Aluminum finishers often used etching as a cleaning process, which generated a considerable amount of unnecessary waste. Caustic etching is a source of considerable waste. Substrates are often over-etched, generating excessive dissolved aluminum. Aluminum preparation for anodizing, chromating or electroplating does not always require etching. Acid etching is commonly substituted for alkaline etchants in aluminum finishing and yields a lighter etch. Non-etch cleaners are available. The printed wiring board (PWB) industry uses a variety of etchants. Considerable effort has been focused on fully-additive processing as an alternative to subtractive processes. PWB etchants include peroxide, ammoniacal, cupric chloride, ferric chloride, and chromic acid.

### **5.7.4 Alternative Cleaning**

Proper cleaning and preparation for finishing is critical. With the environmental controls required for vapor degreasing, a variety of technologies have re-emerged. Typically, the lower vapor pressure cleaners (aqueous, semi-aqueous, etc.) were not used because of the additional rinsing and drying steps required compared to vapor degreasing. Generally, these cleaners have higher soil-bearing capacities than vapor-phase solvents. Efficient rinsing is important, because residues can interfere with subsequent processes or can corrode the part surface. Selection of alternative cleaning equipment, however, is often more important than the chemistry. Many of the alternative cleaning technologies can be operated at elevated temperatures to improve evaporative drying. Hot rinses and air knives are often used to assist drying. With some metals, rust-inhibiting additives are used to prevent corrosion from occurring before final processing is completed. A variety of cleaning equipment is available.

Alternative cleaning processes include aqueous, semi-aqueous, solvent, abrasive blasting and vacuum de-oiling.

### **5.7.5 Alternative Cleaning Equipment**

Various equipment features are added to improve the activity of the cleaner on soils. These features include mechanical agitation, sprays, eductors (fluid jets) and ultrasonics. All act to mechanically remove soils and particles, as well as carry fresh solution to the part surface. Vapor degreasers are still used in strategic applications, particularly in ultra-precision cleaning. The new solvents are expensive (some approaching \$100/gal) and are used in totally enclosed machines. Many shops that used traditional vapor degreasing have switched back to trichloroethylene while other alternatives are investigated. Alternative cleaning equipment includes immersion, spray, spray-under-immersion, ultrasonic, vapor degreasing and hermetically sealed vapor degreasers.

### **5.7.6 Forming and Fabrication**

Improving forming and fabrication processes can often reduce surface finishing requirements. Improved casting methods can reduce surface porosity, improve surface finish, and reduce surface contamination and inclusions. Improved rolling, forging, drawing and stamping can reduce burrs, and likewise reduce surface contamination and inclusions. Improved substrates can also dramatically reduce surface finishing costs by reducing surface preparation. Furthermore, standardizing and maintaining coolants and lubricants can substantially reduce in-process and final cleaning requirements. Depending upon the cleaning process used, petroleum-based lubricants may be easier to clean and/or separate from cleaners. Coordination between forming and fabrication operations and surface finishing operations can pay enormous dividends.

## 6. Existing Processes, Conditions, and Practices

A range of process conditions and practices can be changed to reduce the generation of waste. General approaches are described below, with specific examples listed in Table 6-1:

- (1) Improve facility conditions and housekeeping. General facility conditions and housekeeping practices can be improved to help reduce process bath contamination and overall facility waste generation.
- (2) Reduce process solution drag-out. Reducing process solution drag-out directly reduces process solution contaminant loading to rinse baths and subsequent wastewater treatment systems. Since drag-out removes process bath contaminants as well as beneficial chemicals, the impacts on bath contamination buildup and potential bath purification requirements should be considered when evaluating any drag-out reduction alternative.
- (3) Improve rinsing (reduce drag-in). Improving rinsing performance reduces the carry-over of process bath constituents into subsequent process steps.
  - Improving rinsing efficiency and reducing wasteful rinsing reduces wastewater and conserves water.
- (4) Improve process solution control. Improving process solution control helps maintain production consistency and reduces wastes from less efficient processing, shorter process bath life, or longer processing times. Methods for process solution control range from simple process operations and maintenance procedures to more sophisticated systematic or even automated chemistry monitoring and controls.
- (5) Select and maintain process materials to minimize contamination. Process equipment can contribute to waste generation if not properly selected and maintained for the application. Corrosion-resistant equipment should be selected for new or replacement applications. Maintenance procedures should be developed and followed to maximize equipment life and minimize corrosion, and to avoid spills or upsets.
- (6) Enhance process procedures. A number of process modifications can reduce waste generation. Each process step should be considered for potential beneficial changes.

**Table 6-1.** General Approaches and Specific Techniques for Improving Existing Process Conditions and Practices

General Approach	Specific Technique
Improve Facility Conditions and Housekeeping	<ul style="list-style-type: none"> <li>• Control material purchases to maximize material use and minimize waste</li> <li>• Control air contaminants</li> <li>• Plan and implement programs to avoid spills and minimize wastes from cleanup operations</li> </ul>
Reduce Drag-Out	<ul style="list-style-type: none"> <li>• Use proper rack and barrel design and maintenance</li> <li>• Reduce plating bath viscosity (reduce temperature, concentration, surface tension)</li> <li>• Capture drag-out before rinsing</li> <li>• Install fog or spray rinses</li> <li>• Use drag-out tanks to return chemicals to process tanks</li> <li>• Use multiple drag-out tanks to increase the chemical recovery rate</li> <li>• Adjust part withdrawal and drip times to minimize drag-out</li> </ul>
Improve Rinsing	<ul style="list-style-type: none"> <li>• Control the rate and time of water flow to match process needs</li> <li>• Turn off rinse water when not in use</li> <li>• Use spray rinsing to mechanically remove chemicals and contaminants</li> <li>• Use countercurrent rinsing</li> <li>• Use cascade or reactive rinsing</li> <li>• Track water use</li> </ul>
Improve Process Solution Control	<ul style="list-style-type: none"> <li>• Promptly remove materials that fall into the tanks</li> <li>• Filter baths to remove suspended solids</li> <li>• Use carbon filtration on baths, where effective, to remove contaminant organics</li> <li>• Use conductivity and pH monitoring to detect chemical losses</li> <li>• Implement statistical process monitoring and control</li> <li>• Implement real-time system monitoring and control</li> </ul>
Enhance Process Procedures	<ul style="list-style-type: none"> <li>• Use good cleaning and surface preparation techniques and part inspections to minimize bath contamination and part rework</li> <li>• Define water quality standards and use feed water of appropriate purity</li> <li>• Document and follow good operating procedures</li> <li>• Mask areas not to be processed</li> <li>• Eliminate obsolete processes</li> <li>• Use both soluble and insoluble anodes in the same bath to balance cathode and anode efficiencies</li> <li>• Remove anodes from idle baths where this will reduce metals buildup (e.g., cadmium and zinc anodes)</li> <li>• Nickel plate copper buss bars to reduce the rate of corrosion and bath contamination</li> </ul>

## 7. Conclusions

A variety of management practices and technologies are available to enable surface finishing manufacturers to approach or achieve zero discharge. Individual or combined actions consisting of source reduction, process water recycling, and process substitution need to be considered to determine the best approach for specific applications. Understanding process chemistry and production impacts are essential to the identification, evaluation, and implementation of successful AZD actions. Systematic methods can be used to help managers move effectively through the planning, decision-making, and implementation phases. Systematic considerations can be included in AZD planning to optimize integrated process, environmental, and facility benefits.

Benefits from implementing AZD projects can include: reduced costs, waste generation, and chemical usage, increased regulatory performance, and enhanced facility

operations. However, as zero discharge is approached, the costs for incremental discharge reductions can increase significantly in relation to the benefits achieved.

Suggested areas for additional development to help advance AZD initiatives include:

- Water and rinse water quality standards
- Process solution contaminant standards
- Process pollution prevention and control technology verification data linked to specific applications
- Installed cost and operations and maintenance (O&M) cost survey data corresponding to AZD implementation

## 8. References

- 1) *Benchmarking Metal Finishing*, National Center for Manufacturing Sciences, June 2000.
- 2) Metal Finishing 2000 Guidebook and Directory Issue, *Elsevier Science*, Vol. 98, No. 1, Jan. 2000.
- 3) 21st AESF/EPA Pollution Prevention and Control Conference, Jan. 2000.
- 4) *Products Finishing 2000 Directory and Technology Guide*, Gardner Publications.
- 5) Proceedings: AESF/EPA Conference for Environmental Excellence, Jan. 1999.
- 6) Gallerani, Peter A., *P2 Concepts and Practices for Metal Plating and Finishing*, AESF/EPA Training Course, 1998.
- 7) "19<sup>th</sup> AESF/EPA Pollution Prevention and Control Conference," Jan. 1998.
- 8) "18<sup>th</sup> AESF/EPA Pollution Prevention and Control Conference," Jan. 1997.
- 9) Reinhard, Fred P. and Kevin L. Klink, *Innovative Recycling and Maintenance Technologies for Surface Finishing Operations*, 18<sup>th</sup> AESF/EPA Conference on Pollution Prevention and Control, Jan. 1997.
- 10) "17<sup>th</sup> AESF/EPA Pollution Prevention and Control Conference," Feb. 1996.
- 11) Wick, Charles and Raymond F. Veilleux, *Tool and Manufacturing Engineer's Handbook*, "Materials, Finishing and Coating," Volume 3, 4<sup>th</sup> Edition.
- 12) "Surface Cleaning, Finishing and Coating," *Metals Handbook*, Volume 5, 9<sup>th</sup> Edition.
- 13) Altmayer, Frank, *Pollution Prevention and Control – An Overview*, AESF Press, 1995.
- 14) Higgins, Thomas E., *Pollution Prevention Handbook*, Lewis Publishers, 1995.
- 15) Byers, William, et al., *How to Implement Industrial Water Reuse: A Systematic Approach*, Center for Waste Reduction Technologies – American Institute of Chemical Engineers, 1995.
- 16) Lowenheim, Frederick A., *Electroplating*, Technical Publications, Ltd., Arrowsmith, 1995.
- 17) Cushnie, George, *Pollution Prevention and Control Technology for Plating Operations*, National Center for Manufacturing Sciences, National Association of Metal Finishers, 1994.
- 18) US Department of Commerce, *Advanced Surface Engineering*, NIST GCR 94-640-1.
- 19) Gallerani, Peter A., *Summary Report: Minimization of Metal Finishing Wastes at Pratt and Whitney*, Jan. 1993.



## Appendix A

### Systematic Approach for Developing AZD Alternatives

Systematic AZD planning can be achieved by integrating holistic and specific source reduction assessment, including considerations for multiple sources, composite solutions, life cycle design and facility optimization.

Systematic AZD solutions can be relatively easy to develop, or may require extensive data collection, scenario development and failure analysis. Accurate data collected from technologies and process changes are needed to evaluate case-specific application potential. Evaluation tools such as process modeling and demonstration projects help to determine future needs. A combination of in-plant and outside expertise helps to focus AZD implementation encompassing a range of applicable solutions. The level of effort needed to pursue systematic solutions enables the decision makers to weigh the potential value gain toward implementing a systematic AZD solution.

#### Step 1. Establish Goals

Establishing goals provides a foundation for an AZD project. As the project progresses, goals and priorities can be revisited and adjusted as deemed appropriate. Although the objective is to proceed with minimal changes, the process can lead to new information that results in decisions towards beneficial changes in goals and priorities. For goals to be implemented effectively, they should be specific, appropriate and measurable.

Goals directly or indirectly related to AZD are to:

- Achieve discharge reduction targets.
- Stay within budgets and meet payback timeframes.
- Achieve regulatory compliance and beyond-compliance targets.
- Improve process consistency and quality.
- Improve plant space use.
- Meet schedule targets.

#### Step 2. Identify Opportunities

AZD opportunities can be identified for individual process solutions, process lines, multi-process lines, or entire

process facilities. Opportunities should be identified where discharge reductions can solve discharge-related problems, or can otherwise benefit production operations and overall costs.

General steps to identify viable AZD opportunities:

- *List discharges and sources for potential reduction.* Wastewater treatment and waste disposal data need to be reviewed to provide information on discharges from process baths and rinses. Discharges can be associated with specific upstream, in-plant sources. Depending on the available data and the level of complexity of the facility processes, it may be necessary to perform a plant-wide process survey to identify specific waste sources.
- *Characterize sources and discharges.* The type and magnitude of each identified discharge should be estimated, including constituents, mass and volumetric rate, and variation with time (for projected production type and level). Table A-1 presents data objectives for characterizing sources and discharges. This can include a combination of measurements and analyses, calculations, and modeling.
- *Identify drivers and benefits.* Identifying drivers and benefits for source-specific zero discharge opportunities helps provide a basis for setting AZD goals. Benefits associated with source-specific reductions include a range of net cost and no-cost gains or improvements that would result directly or indirectly from actions implemented to reduce waste discharges. Table A-2 lists common AZD benefits. Drivers are major benefits that represent primary reasons for implementing source-specific AZD alternatives.
- *Identify impediments.* Constraints represent limitations that apply to source-specific AZD considerations. Table A-3 lists some common constraints. After constraints are identified, assess whether measures could be implemented to remove the constraints. For example, if a capital-cost ceiling is identified for a project, it might be possible to finance the capital project with no increase, or even a reduction in net short-

**Table A-1.** Data Requirements for Characterizing Sources and Discharges

Waste quantity and characterization data	Bath dumps, wastewater discharge flow and analyses, waste chemicals and raw materials, information on spills or process upsets, and residuals and byproducts from process purification and treatment systems (including routine operations and wastes from periodic cleaning and maintenance)
Production information	Process sequences and bath chemistries, process specifications, component data (type, size, throughput, and output), bath chemistry additions, rectifier amp-hours totals (specific to production periods), part rejects and reprocessing
Wastewater treatment chemical additions	Chemical quantity and frequency of addition
Water supply characteristics	Total dissolved solids, conductivity/resistivity, hardness, temperature, pH, specific ions
Chemical use and wastes from water pretreatment processing	Chemical quantity and frequency of addition

**Table A-2.** Common AZD Benefits

Overall Benefits	Specifications
Reduced costs	Capital costs (e.g., overall capital costs for new projects that include new or expanded wastewater treatment systems may have reduced capital costs due to more focus on in-plant discharge reductions), operating costs, and life-cycle costs
Reduced waste generation	Wastewater, wastewater treatment residuals, bath dumps, process bath and rinse treatment wastes
Production improvements	Reduced rejects, reduced processing variability, improved product consistency and quality, updated/increased capacity
Reduced chemical use	Surface finishing bath chemicals, wastewater treatment chemicals, process maintenance treatment chemicals
Increased regulatory performance	Compliance or beyond-compliance performance, wastewater discharges, air emissions, hazardous wastes, and toxic chemical use
Enhanced facility operations	Space availability, energy consumption, safety, and reduction of water use
Enhanced environmental and production performance	Corporate goals, customer requirements, environmental metrics

**Table A-3.** Common AZD Constraints

Constraints	Specifications
Financial	Capital spending limits, payback timeframe requirements
Process	Limitations on changing processes
Facility	Space or location limitations that could impact plant modifications or the addition of new systems
Equipment	Existing equipment that must be used or must stay at a fixed location
Operational	Limited operator availability and capabilities
Regulatory	Multimedia permit requirements or triggers
Schedule	Difficult requirements for project milestones and completion
Data	Limited process data and ability to gather project data

term cash flow due to operational cost savings. Removing a short-term capital ceiling constraint could lead to significant net cost savings over the long term.

### Step 3. Identify and Screen Alternatives

A preliminary range of plausible alternatives for AZD should be identified to address specific AZD opportunities. To gain a full perspective on potential costs and benefits of AZD, it is often beneficial to consider alternatives that range from simple process modifications to more comprehensive process enhancements. General types of AZD alternatives include:

- Process solution purification systems (Section 3)
- Process rinse water recycle systems (Section 4)
- Alternative processes (Section 5)
- Improving existing processes and operations (Section 6)

Prior to more detailed evaluations, preliminary alternatives should be screened to eliminate those that have serious flaws. This will result in a range of specific alternatives for detailed evaluation. Another important level of consideration for AZD alternatives are systematic approaches, which provide enhanced solutions for multiple AZD opportunities, and integrate overall facility and life cycle considerations. Section 2 discusses systematic AZD approaches.

Target alternatives need to be defined to provide scenarios that can be evaluated in accordance with application-specific requirements. The information needed to build a scenario for an AZD alternative varies substantially with the type of alternative. It is important to consider the complete implementation requirements, including plant and process interfaces, and construction and operations requirements.

### Step 4. Evaluate Alternatives

Alternatives that have passed initial screening should be thoroughly evaluated using a consistent, systematic evaluation method encompassing evaluation categories and evaluation metrics. Typical evaluation categories are described below. Table A-4 lists specific evaluation criteria for each category.

- *Technical Feasibility.* Technical feasibility evaluations typically involve identification of essential implementation and operational performance criteria for an alternative. Relevant information is collected and evaluations are performed to determine how each alternative corresponds with the technical criteria. For some applications, it may be necessary to perform more extensive evaluations, including bench and/or pilot testing to determine technical feasibility. The

technical criteria vary depending on the type of alternative and specific impacts on the facility and its processes and operations.

- *Cost.* Cost evaluations include developing capital and operations and maintenance (O&M) estimates for AZD alternatives and comparing costs for existing operations. Projections for future production requirements need to be included as a basis for cost estimating.
- *Regulatory.* Regulatory evaluations identify applicable regulations and performance requirements that determine how specific AZD alternatives fall short of, achieve, or exceed the requirements and guidelines.
- *Company/staff acceptability.* Company and staff acceptability evaluations assess how AZD fits a specific application from the operator to corporate management. Evaluations of AZD alternatives can be based on a range of qualitative (e.g., high, medium, or low) or quantitative (e.g., 1 to 10) metrics specific to each evaluation category. A matrix format is often useful to summarize alternative evaluations. In some cases, evaluation results are combined from different categories into a single overall score for each alternative. This involves development of a consistent scoring basis and category-specific weightings to allow for calculation of an overall score.

Decision analysis methods may assist in evaluating large, complex AZD applications when alternatives depend on highly variable production scenarios and when expected costs and benefits vary greatly. Powerful decision analysis software tools are available that generate ranges of probabilistic outcomes and delineate key variable impacts.

### Step 5. Select Action(s)

Specific actions need to be selected based on the best individual or combination of alternatives to satisfy short and long-term needs. Actions can be implemented in one or more phases to satisfy project-specific resource limitations, sequencing to maintain operations, and priorities for achieving maximum results. Lastly, project funding and implementation support should be secured to allow for implementation within desired project timeframes.

### Step 6. Implement Action(s)

Successful AZD solutions require good implementation to gain the desired reductions and cost benefits. Technical, strategic, and management experience is important throughout each general implementation phase to achieve overall success with AZD projects. General implementation phases include:

1. *Develop a design basis.* Fixed and variable facility data, site factors, production requirements, and process parameters are essential in the design

**Table A-4.** AZD Alternative Evaluation Criteria

Evaluation Category	Specific Criteria or Parameter
Technical Feasibility	Ability to maintain process chemistry, recovery percentages for water recycle or chemical recovery, reliability, operability, facility space and interface requirements, level of technology and applications development, byproducts and waste generation
Cost: Capital	Engineering, process modifications or new process systems, pollution prevention and control systems, facility costs, utility connections and plant interfaces, training, start-up and commissioning, general construction and implementation, permitting and regulatory, plant space, cost of money, internal coordination and administration costs
Cost: Operation & Maintenance (O&M)	Operations labor for new or modified process systems, utility costs, chemicals and consumable materials, analytical requirements, and management of byproducts from new process maintenance systems
Regulatory	Permitting, data collection, record keeping and reporting, and compliance requirements and guidelines, voluntary and beyond-compliance programs
Company and Staff Acceptability	Company policies, standards, and goals relevant to AZD including preferences and dislikes of AZD decision makers, owners, and implementers for specific AZD alternatives

Comprehensive cost evaluations include capital and O&M cost savings with AZD alternatives compared to existing operations. Table A-5 lists common capital and O&M cost savings and benefits that may result from implementing AZD actions.

**Table A-5.** Cost Savings and Benefits for AZD Actions

---

#### **Major Capital Cost Savings and Benefits**

- Downsized wastewater treatment requirements
- Salvage value or reuse of existing equipment
- Gain in plant space (e.g., with downsized wastewater treatment systems)
- Gain in tax credits
- Additional project funding resources

#### **Major O&M Cost Savings and Benefits**

- Reduced rework and rejects
  - Increased revenue and/or cost to produce – product quality improvements, increased throughput or yield, and decreased effort to produce
  - Reduced waste management costs — bath dumps, wastewater treatment and discharge
  - Reduced process bath chemistry costs
  - Reduced water supply and pretreatment costs
  - Reduced insurance and liability costs
  - Gained revenues from byproducts
-

factors. Pilot testing may be necessary to verify technical assumptions.

2. *Prepare the design.* The type and level of design (ranging from performance-based design to detailed design) should be appropriate for the application.
3. *Procure systems and services.* Implementation needs to be appropriate for the application.
4. *Perform installation and startup.* Careful planning and coordination in implementing new systems minimizes disruptions to existing operations.
5. *Perform ongoing implementation.* New systems or procedures need to operate in accordance with

well-defined plans (O&M plan or procedure protocol).

6. *Monitor operations and identify improvements.* Pre-defined monitoring identifies potential problems or possible enhancements that might require additional process changes.

### **Step 7. Follow-up Monitoring and Actions**

Scheduled monitoring of AZD systems will determine whether the actions taken are being executed properly and that the desired results have been achieved. Changes needed to optimize or enhance the system may be identified through ongoing monitoring of actions and results.

## Appendix B Installed Costs

This Appendix provides a limited overview of typical installed capital costs for control technologies and process changes for approaching zero discharge (AZD) in the surface finishing industry. Many approaches are presented in this document for process solution purification and recovery, rinse purification/concentrate recovery, alternative surface finishing processes and coatings, and for improving existing process conditions and practices. Table B-1 presents representative ranges of installed capital costs that are size- and approach-specific. Described below are representative projects that would be expected to fall within the Table B-1 cost ranges for project sizes defined as small, medium, large, and very large.

### B.1 Process Solution Purification and Recovery (Section 3)

Examples corresponding to the process purification and recovery cost ranges in Table B-1:

#### Small

- A 100-gallon per day throughput microfiltration system to maintain an alkaline cleaner bath at a target contaminant concentration at less than 250 ppm soil, with 100 g/day contaminant loading.
- A diffusion dialysis or resin sorption system to purify 20 gallons per day of Type 2 sulfuric acid anodize bath with an aluminum concentration of 10 g/L, recovering more than 80% of free acid.

#### Medium

- A 500-gallon per day throughput microfiltration system to maintain three alkaline cleaner process baths at less than 250-ppm soil with overall 500-g/day contaminant loading.
- A diffusion dialysis or resin sorption system to purify 100 gallons per day of Type 2 sulfuric acid anodize bath with an aluminum concentration of 10 g/L, recovering more than 80% of free acid.

#### Moderately large

- A 500-gallon per day throughput microfiltration system to maintain three alkaline cleaner process baths at less than 250-ppm soil with overall 500 g/day contaminant loading.
- A diffusion dialysis or resin sorption system to purify 250 gallons per day of Type 2 sulfuric acid anodize bath with an aluminum concentration of 10 g/L, recovering more than 80% of free acid.

#### Large

- Diffusion dialysis system to reclaim 5,000 gallon per day of hydrochloric acid 7 wt % waste hydrochloric acid steel pickle stream with 4 wt % iron. Reclaimed acid to have less than 1 wt % iron.
- Membrane electrolysis system for maintaining a full production, 50,000 gallon chromate conversion coat bath, to remove and maintain total

**Table B-1:** Installed Capital Cost Ranges for Typical AZD Project Approach and Size Ranges

AZD Approach	Installed Capital Cost (in thousands of dollars)			
	Project Size			
	Small <sup>1</sup>	Medium <sup>2</sup>	Moderately Large <sup>3</sup>	Large <sup>4</sup>
Process Technique	< 5	5 to 20	20 to 100	100 to 500
Water Purification/Recycle	< 20	20 to 100	100 to 500	500 to 2500
Bath Purification	< 20	20 to 100	100 to 500	500 to 2500
Process Replacement	20 to 100	100 to 500	500 to 2500	2500 to 10000

<sup>1</sup> A point-source-purification system for a single small to medium-sized surface finishing bath with low to moderate contaminant loading.

<sup>2</sup> A point-source-purification system for multiple small to moderate-sized baths with low to moderate contaminant loading.

<sup>3</sup> A bath maintenance system for a relatively large process bath or process baths with low to moderate contamination or several bath maintenance systems for a medium-sized shop.

<sup>4</sup> Several multi-tank bath maintenance systems for a moderate to large shop or single bath maintenance systems for very large process tanks.

contaminant (iron, aluminum, and copper) concentration below 1 g/L and to reoxidize trivalent chromium to hexavalent chromium.

## B.2 Rinse Purification/Concentrate Recovery (Section 4)

Examples corresponding to the rinse purification cost ranges in Table B-1:

- **Small**

Single rinse point source ion exchange system, equipped with a manual regeneration system, for water purification/recycle of a 1 to 3 gpm nickel plating rinse system with 300 ppm TDS influent and 10 ppm TDS rinse water purification required.

- **Medium project:**

A 5 to 20 gpm ion exchange system or reverse osmosis system for purification/recycle of several nickel plating rinses with 300 ppm TDS influent and 10 ppm TDS rinse water purification required. The ion exchange system would be equipped with an automatic, PLC-controlled regeneration system. The reverse osmosis system would be PLC-controlled.

- **Moderately Large**

A 50 to 100 gpm ion exchange system or reverse osmosis system for centralized purification/recycle of several compatible metal finishing process rinses with 100 ppm TDS influent and 10 ppm TDS rinse water purification required. The ion exchange system would be equipped with an automatic, PLC-controlled regeneration system. The reverse osmosis system would be PLC-controlled.

- **Large**

A 100 to 1000 gpm combined reverse osmosis system followed by ion exchange system for centralized purification/recycle of several compatible metal finishing process rinses with 100 ppm TDS influent and 2 ppm TDS rinse water purification required. The overall system includes complete redundant reverse osmosis modules and ion exchange resin beds to maintain highly reliable continuous operations. The ion exchange system would be equipped with an automatic, PLC-controlled regeneration system. The reverse osmosis system would be PLC-controlled.

## B.3 Alternative Surface Finishing Processes and Coatings (Section 5)

Examples corresponding to the alternative surface finishing processes and coatings cost ranges in Table B-1:

- **Small**

- Change anodizing chemistry on small or medium-sized line from chromic acid to sulfuric/boric acid.

- **Medium**

- Change anodizing chemistry on large line from chromic acid to sulfuric/boric acid.

- **Moderately Large**

- Small electrocoat line for 10,000-sq ft per day production.
- Limited production single chamber scale batch vapor deposition system.

- **Large**

- Electrocoat line for 100,000-sq ft per day production.
- Fully automated production scale continuous vapor deposition system.

## B.4 Improving Existing Process Conditions and Practices (Section 6)

Examples corresponding to the Table B-1 cost ranges for improving existing process conditions and practices:

- **Small**

- Implement more frequent bath chemistry monitoring and maintenance for single process bath.
- Install fog or spray rinses on several small tanks.
- Add water conductivity controller for single rinse water make-up.

- **Medium**

- Add automated chemistry monitoring and maintenance for a single electroless nickel bath
  - Add water purification system for 5-gpm city water supply with 100-ppm TDS to provide <10-ppm TDS influent process water.
  - Add water conductivity controller for automatic rinse water make-up for several tanks.

- **Moderately large**

- Add automated chemistry monitoring and maintenance for several electroless nickel baths
  - Install 50-gpm water purification system for city water supply with 100-ppm TDS to provide <10-ppm TDS influent process water.
  - Install three triple countercurrent rinse systems with 200-gallon tanks.
  - Add automated feed and bleed systems for maintaining more uniform process chemistry for four, 500-gallon metal finishing process tanks with a combined total of seven different

process make-up chemistries and three segregated bleed waste streams.

### Large

- Install six triple countercurrent rinse systems with 500-gallon tanks.
- Install 500-gpm water purification system for city water supply with 100-ppm TDS to provide <10-ppm TDS influent process water.
- Add automated feed and bleed systems for maintaining more uniform process chemistry for ten 500-gallon metal finishing process tanks with a combined total of 12 different process make-up chemistries and four wastewater treatment streams.

### **Factors Influencing Installed Costs**

Installed costs for process systems can vary significantly depending on many site-specific and other project-specific factors that can affect system, installation, and operational requirements. These factors should be considered when extrapolating costs from other installations or when estimating installed costs from equipment only. Project budgets are often set prior to consideration of these factors, frequently leading to insufficient funding and corresponding delays and cost increases for overall project implementation. Some common factors that can significantly impact implementation costs for process or production systems for AZD projects include:

- *Relative inlet and required outlet concentrations for process systems.* Differences in overall percent removal and final concentrations may require supplemental pretreatment or post-treatment unit processes. It is important to adequately characterize process streams and their inherent variability, and define the outlet process fluid purity requirements for estimating specific process system requirements and costs.
- *Materials of construction.* Equipment material requirements may vary significantly based on the chemicals and concentrations handled, along with required effluent process fluid purity requirements. If premium materials of construction are required, costs can increase greatly compared to typical systems costs with standard materials of construction. If the need for specialty materials is not recognized until after installation, this can result in significant costs for equipment maintenance and early replacement.

- *Site installation.* Installation requirements and costs may vary significantly, even for identical process systems, installed at different project locations. Site installation costs can range from a fraction to a total multiplier of equipment costs. Some modular, skid-mounted systems can be easily set in place and quickly connected to utilities and fluid inlet and outlets. Other process systems or locations can require a combination of facilities modifications or expansions, utility upgrades, seismic restraints, or other significant site work to complete installation.
- *Start-up and commissioning requirements.* Process system or client-specific requirements can vary substantially for start-up and commissioning, ranging from a few hours to weeks. The extent of these requirements and the degree of proper installation and systems application implementability can significantly impact the duration and effort required to meet these requirements. Unanticipated installation and operation difficulties can result in significant schedule and cost impacts for systems start-up and commissioning.
- *Process system redundancy/reliability.* Application-specific redundancy and reliability requirements can impact the number of parallel and/or series process trains, with corresponding multiple or additive system costs.
- *Level of automation.* Local and centralized instrumentation and control requirements for process automation can vary significantly. Where automation can significantly increase initial capital costs, overall life cycle costs can be reduced due to improved production efficiencies.
- *Equipment quality.* Process systems may vary significantly in quality and corresponding capital costs. In evaluating comparative systems it is important to consider the comparative life cycle costs for systems. Higher-priced, better-quality systems may provide longer and more trouble-free service life, thereby reducing overall life cycle costs.
- *Location specific configuration requirements.* Facility-specific footprint space and height requirements may require custom system configurations and corresponding custom system design and fabrication, increasing costs compared to standard off-the-shelf systems.



- *Allowances for production expansion and flexibility.* When considering AZD-related replacement process systems or process systems that interface with primary production systems (e.g., water recycle or process bath maintenance systems) it is important to consider and plan for production expansion and potential

production changes. Proper allowances for production expansion and/or changes may result in significant increases in short-term AZD-related capital costs but may reduce future costs related to systems modification, expansion, or replacement in response to production increases and/or changes.